

**Notes:**

ITEM #	REF. SHEET	DETAIL	CSI SECT	DESCRIPTION	QTY.	WASTAGE	QTY WITH WASTAGE	UNIT	UNIT LABOR COST	UNIT MATERIAL COST	TOTAL LABOR COST	TOTAL MATERIAL COST	ITEM COST	TRADE COST
			DIV-01	<b>GENERAL</b>										\$ -
1				Permit	1	0%	1	LS			\$ -	\$ -	\$ -	
2				Supervision	1	0%	1	LS			\$ -	\$ -	\$ -	
3				Final Cleanup	1	0%	1	LS			\$ -	\$ -	\$ -	
4				Mobilization Cost	1	0%	1	LS			\$ -	\$ -	\$ -	
5				Project Overheads	1	0%	1	LS			\$ -	\$ -	\$ -	
6				Bonds	1	0%	1	LS			\$ -	\$ -	\$ -	
7				Fees (Architect & Engineer)	1	0%	1	LS			\$ -	\$ -	\$ -	
8				Temporary Control & Facilities	1	0%	1	LS			\$ -	\$ -	\$ -	
			DIV-22	<b>Plumbing</b>										\$ -
				<b>Site Plan</b>										
#	P-6	Plumbing Site Plan		New 2" Type K Copper Underground Main Water Line	10	5%	10	LF			\$ -	\$ -	\$ -	
#				New 2" Domestic Water Meter	1	0%	1	EA			\$ -	\$ -	\$ -	
#				New 2" Water Backflow Preventor	1	0%	1	EA			\$ -	\$ -	\$ -	
#				New 2" Natural Gas Meter	1	0%	1	EA			\$ -	\$ -	\$ -	
#				Underground 1000 Gallon Grease Interceptor MFR: WATTS MODEL: WD-50-A	1	0%	1	EA			\$ -	\$ -	\$ -	
				<b>Sewer Plumbing Plan</b>										
#	P-1	Sewer Plumbing Plan		2" Sewer Line	100	5%	105	LF			\$ -	\$ -	\$ -	
#				3" Sewer Line	9	5%	9	LF			\$ -	\$ -	\$ -	
#				4" Sewer Line	169	5%	177	LF			\$ -	\$ -	\$ -	
#				2" Grease Sewer Line	87	5%	92	LF			\$ -	\$ -	\$ -	
#				3" Grease Sewer Line	12	5%	13	LF			\$ -	\$ -	\$ -	
#				4" Grease Sewer Line	83	5%	88	LF			\$ -	\$ -	\$ -	
#				WH-1: Water Heater MFR: Rheem-Ruud Model: XG50 or Equal	1	0%	1	EA			\$ -	\$ -	\$ -	
#				FCO: Floor Cleanout	8	0%	8	EA			\$ -	\$ -	\$ -	
#				WCO: Wall Cleanout	7	0%	7	EA			\$ -	\$ -	\$ -	
#				1000 Gallon Grease Interceptor MFR: WATTS MODEL: WD-50-A	1	0%	1	EA			\$ -	\$ -	\$ -	
				<b>Water Plumbing Plan</b>										
#	P-3	Water Plumbing Plan		1" Cold Water Pipe	12	5%	13	LF			\$ -	\$ -	\$ -	
#				1/2" Cold Water Pipe	50	5%	52	LF			\$ -	\$ -	\$ -	
#				2" Cold Water Pipe	197	5%	207	LF			\$ -	\$ -	\$ -	
#				3/4" Recirculation Hot Water Pipe	95	5%	100	LF			\$ -	\$ -	\$ -	
#				3/4" Hot Water Pipe	22	5%	23	LF			\$ -	\$ -	\$ -	
#				1/2" Hot Water Pipe	136	5%	143	LF			\$ -	\$ -	\$ -	
#				1" Hot Water Pipe	14	5%	14	LF			\$ -	\$ -	\$ -	
#				3/4" Fresh Water Pipe	121	5%	127	LF			\$ -	\$ -	\$ -	
#				2" Type K Copper Main Water Pipe	5	5%	6	LF			\$ -	\$ -	\$ -	
#				3/4" Shut of Valve	1	0%	1	EA			\$ -	\$ -	\$ -	
#				Vacuum Breaker Valve	1	0%	1	EA			\$ -	\$ -	\$ -	

#			Water Filter	1	0%	1	EA		\$ -	\$ -	\$ -
#			Water Softner	1	0%	1	EA		\$ -	\$ -	\$ -
#			Expansion Tank	1	0%	1	EA		\$ -	\$ -	\$ -
#			CP-1: Automatic Circulating Pump	1	0%	1	EA		\$ -	\$ -	\$ -
#			1/2" Shut-off Valve	1	0%	1	EA		\$ -	\$ -	\$ -
#			Check Valve	1	0%	1	EA		\$ -	\$ -	\$ -
#			Back Flow Preventor	5	0%	5	EA		\$ -	\$ -	\$ -
#			1" Flush-Ometer Manual Valve	4	0%	4	EA		\$ -	\$ -	\$ -
#			1" Manual Valve	1	0%	1	EA		\$ -	\$ -	\$ -
#			1" Water Hammer Arrestor Valve	1	0%	1	EA		\$ -	\$ -	\$ -
<b>Gas Plumbing Plan</b>											
#	P-4	Gas Plumbing Plan	2" Gas Pipe	42	5%	44	LF		\$ -	\$ -	\$ -
#			3/4" Gas Pipe	9	5%	10	LF		\$ -	\$ -	\$ -
#			Gas Fryer Manufacture Model: By Owner	3	0%	3	EA		\$ -	\$ -	\$ -
#			Rice Cooker Manufacture Model: By Owner	4	0%	4	EA		\$ -	\$ -	\$ -
#			Burner Range Manufacture Model: By Owner	2	0%	2	EA		\$ -	\$ -	\$ -
<b>Plumbing Fixtures</b>											
#	P-6	Plumbing Fixtures	Water Closet -American Standard Cadet Elongated Toilet -Model # 2998.012 ( ADA)	4	0%	4	EA		\$ -	\$ -	\$ -
#			Lavatory MFR / Model: By Contractor	4	0%	4	EA		\$ -	\$ -	\$ -
#			MOP Sink MFR / Model: By Food Service Plans	1	0%	1	EA		\$ -	\$ -	\$ -
#			3 Compartment Sink MFR / Model: By Food Service Plans	1	0%	1	EA		\$ -	\$ -	\$ -
#			Hand Sink MFR / Model: By Food Service Plans	5	0%	5	EA		\$ -	\$ -	\$ -
#			Prep Sink MFR / Model: By Food Service Plans	1	0%	1	EA		\$ -	\$ -	\$ -
#			Dump Sink MFR / Model: By Food Service Plans	3	0%	3	EA		\$ -	\$ -	\$ -
#			Floor Sink & Floor Drain MFR / Model: By Food Service Plans	9	0%	9	EA		\$ -	\$ -	\$ -
#			Make Air Unit	1	0%	1	EA		\$ -	\$ -	\$ -
#			Dishwasher	1	0%	1	EA		\$ -	\$ -	\$ -
#			Hose Bibb	1	0%	1	EA		\$ -	\$ -	\$ -
#			Irrigation System	1	0%	1	EA		\$ -	\$ -	\$ -
DIV-23			HVAC								\$ -
<b>Mechanical Plan</b>											
<b>Ducts</b>											
#			12" Dia Supply Air Duct	62	5%	66	LF		\$ -	\$ -	\$ -
#			16" Dia Flexible Duct	47	5%	50	LF		\$ -	\$ -	\$ -
#			14" Dia Supply Air Duct	57	5%	60	LF		\$ -	\$ -	\$ -
#			10" Dia Supply Air Duct	12	5%	13	LF		\$ -	\$ -	\$ -
#			8" Dia Supply Air Duct	63	5%	66	LF		\$ -	\$ -	\$ -
#			6" Dia Supply Air Duct	9	5%	9	LF		\$ -	\$ -	\$ -
#			16" Dia Supply Air Duct	13	5%	14	LF		\$ -	\$ -	\$ -
#			18" Dia Supply Air Duct	15	5%	16	LF		\$ -	\$ -	\$ -
#			8" Dia Flexible Duct	52	5%	54	LF		\$ -	\$ -	\$ -
#			6" Dia Flexible Duct	15	5%	16	LF		\$ -	\$ -	\$ -
#			14" Dia Flexible Duct	33	5%	35	LF		\$ -	\$ -	\$ -
#			12" Dia Flexible Duct	34	5%	35	LF		\$ -	\$ -	\$ -
#			10" Dia Flexible Duct	6	5%	7	LF		\$ -	\$ -	\$ -
#			10" x 21" Supply Air Duct	55	5%	58	LF		\$ -	\$ -	\$ -
#			10" x 16" Supply Air Duct	11	5%	12	LF		\$ -	\$ -	\$ -
#			14" x 16" Supply Air Duct	59	5%	62	LF		\$ -	\$ -	\$ -
#			20" x 16" Supply Air Duct	33	5%	35	LF		\$ -	\$ -	\$ -
#			24" x 16" Supply Air Duct	4	5%	4	LF		\$ -	\$ -	\$ -
#			28" x 24" Supply Air Duct	23	5%	25	LF		\$ -	\$ -	\$ -

#		20" x 20" Supply Air Duct	13	5%	13	LF		\$ -	\$ -	\$ -
#		16" x 16" Supply Air Duct	19	5%	19	LF		\$ -	\$ -	\$ -
#		24" x 20" Supply Air Duct	7	5%	7	LF		\$ -	\$ -	\$ -
#		3/4" PVC Condensate Drain	32	5%	33	LF		\$ -	\$ -	\$ -
#		18" Dia Grease Duct	17	5%	18	LF		\$ -	\$ -	\$ -
#		10" Dia Exhaust Duct	8	5%	9	LF		\$ -	\$ -	\$ -
#		4" Dia New Type B Flue Vent Thru Roof	10	5%	11	LF		\$ -	\$ -	\$ -
#		<b>Exhaust Fan</b>								
		EF-1,2,3,4,5: Ceiling Exhaust Fan MFR & Model No: Broan 80 E.S.P: .125 Volts/P/HZ: 120/1/60 Operation Weight(LBS): 8.5	5	0%	5	EA		\$ -	\$ -	\$ -
#		<b>Grilles &amp; Registers</b>								
		A: Supply Air Ceiling Register (CFM=350) MFR & Model: HART & COOLEY/ARE Size(inch): 24" x 24" Material: Steel	1	0%	1	EA		\$ -	\$ -	\$ -
#		A: Supply Air Ceiling Register (CFM=500) MFR & Model: HART & COOLEY/ARE Size(inch): 24" x 24" Material: Steel	8	0%	8	EA		\$ -	\$ -	\$ -
#	M2	A: Supply Air Ceiling Register (CFM=400) MFR & Model: HART & COOLEY/ARE Size(inch): 24" x 24" Material: Steel	5	0%	5	EA		\$ -	\$ -	\$ -
#	Mechanical Plan	A: Supply Air Ceiling Register (CFM=200) MFR & Model: HART & COOLEY/ARE Size(inch): 24" x 24" Material: Steel	8	0%	8	EA		\$ -	\$ -	\$ -
#		A: Supply Air Ceiling Register (CFM=430) MFR & Model: HART & COOLEY/ARE Size(inch): 24" x 24" Material: Steel	2	0%	2	EA		\$ -	\$ -	\$ -
#		A: Supply Air Ceiling Register (CFM=360) MFR & Model: HART & COOLEY/ARE Size(inch): 24" x 24" Material: Steel	1	0%	1	EA		\$ -	\$ -	\$ -
#		B: Supply Air Ceiling Register (150 CFM) MFR & Model: HART & COOLEY/ARE Size(inch): 16" x 16" Material: Steel	1	0%	1	EA		\$ -	\$ -	\$ -
#		B: Supply Air Ceiling Register (70 CFM) MFR & Model: HART & COOLEY/ARE Size(inch): 16" x 16" Material: Steel	4	0%	4	EA		\$ -	\$ -	\$ -
#		B: Supply Air Ceiling Register (200 CFM) MFR & Model: HART & COOLEY/ARE Size(inch): 16" x 16" Material: Steel	2	0%	2	EA		\$ -	\$ -	\$ -
#		C: Return Air Transfer Grille MFR & Model: HART & COOLEY/HX Size(inch): 24" x 24" Material: Steel	12	0%	12	EA		\$ -	\$ -	\$ -
#		D: SupplyAir Ceiling Register MFR & Model: HART & COOLEY/RZ Size(inch): 24" x 24" Material: Steel	2	0%	2	EA		\$ -	\$ -	\$ -
#		Supply Air Built In Register	6	0%	6	EA		\$ -	\$ -	\$ -
#		<b>Fixtures</b>								
#		EH-1: Kitchen Exhaust Hood	1	0%	1	EA		\$ -	\$ -	\$ -
#		EH-2: Kitchen Exhaust Hood	1	0%	1	EA		\$ -	\$ -	\$ -
#		EH-3: Kitchen Exhaust Hood	1	0%	1	EA		\$ -	\$ -	\$ -
#		Thermostat	5	0%	5	EA		\$ -	\$ -	\$ -





#	E4	Electrical Rooftop Plan	Wiring											
			Electrical Wiring	64	5%	67	LF			\$ -	\$ -	\$ -		
			Fixtures											
#			30A, 240V, 3 Pole Fused Disconnect Switch	6	0%	6	EA			\$ -	\$ -	\$ -		
#			60A, 240V, 3 Pole Fused Disconnect Switch	5	0%	5	EA			\$ -	\$ -	\$ -		
#	120V, GFCI Weather Protection Receptacle	6	0%	6	EA			\$ -	\$ -	\$ -				
	<b>SUB TOTAL</b>						<b>Total Lab. Cost =</b>		\$ -	<b>Total Mat. Cost =</b>	\$ -	\$ -	\$ -	
	<b>INSURANCE</b>						<b>0%</b>				\$ -	\$ -	\$ -	
	<b>OVERHEAD AND PROFIT</b>						<b>25%</b>				\$ -	\$ -	\$ -	
	<b>TOTAL BASE BID</b>										\$ -	\$ -	\$ -	

Construction Estimations LLC

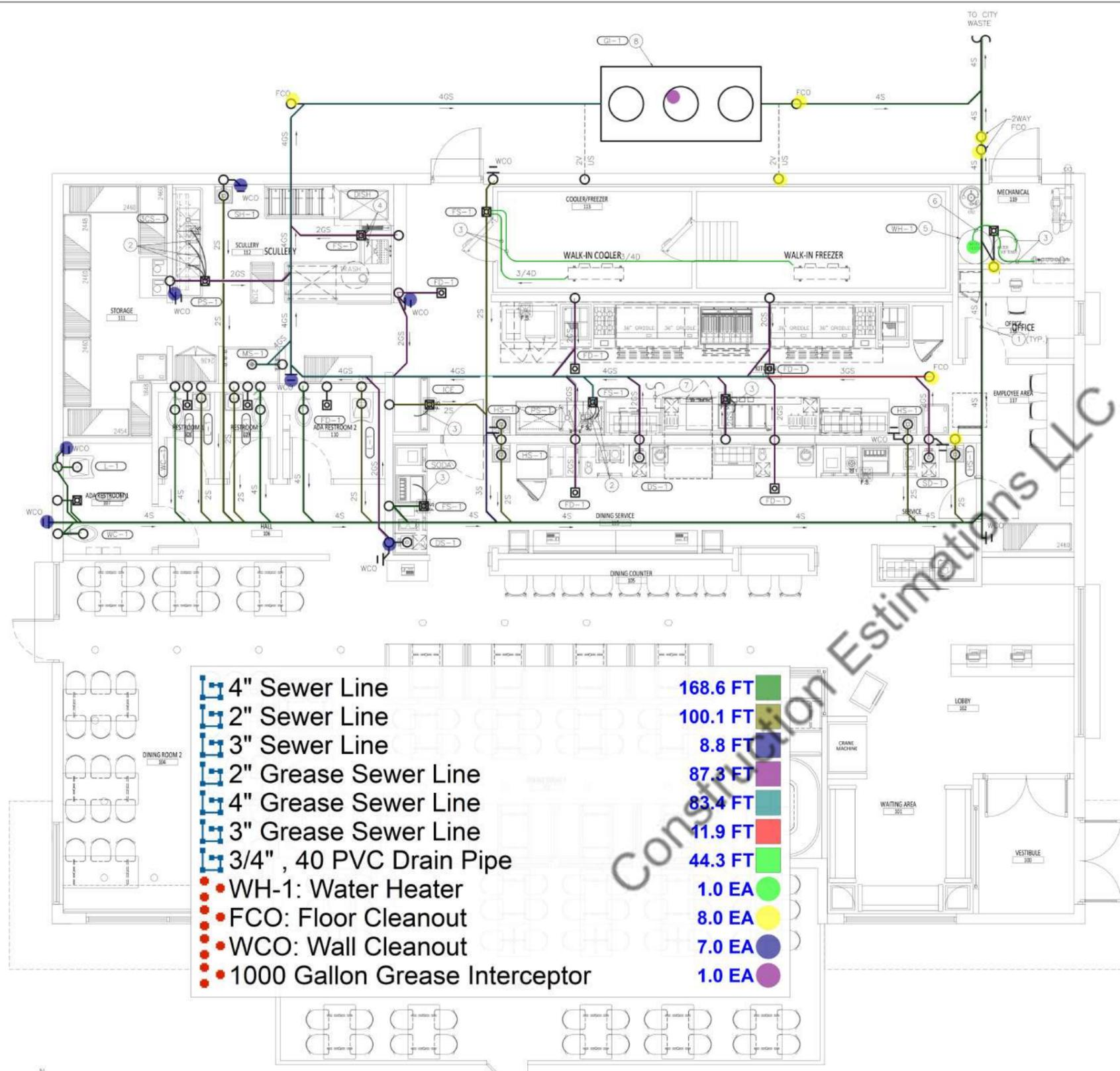

**SEWER PLUMBING PLAN**  
SCALE: 1/4" = 1'-0"

**GENERAL NOTES**

ALL PLUMBING DESIGN AND CONSTRUCTION TO BE ACCORDING WITH 2018 IPC

**PLUMBING LEGEND** (NOT ALL USED)

- N) NEW
- E) EXISTING
- R) RELOCATE
- X) REMOVE
- A.C. ABOVE CEILING
- U.S. UNDER SLAB
- POC POINT OF CONNECTION
- BFP BACKFLOW PREVENTOR
- WC TOILET
- L LAVATORY
- HS HAND SINK
- FS FLOOR SINK
- HB HOSE BIBB
- MS MOP SINK
- 3CS THREE COMPARTMENT SINK
- OFD OVERFLOW DRAIN LINE
- ST SOLID TRAP
- FCV FLOW CONTROL VALVE
- G NATURAL GAS LINE
- GS GREASE SEWER LINE
- CW COLD WATER
- HW HOT WATER
- WH WATER HEATER
- TP TRAP PRIMER
- VTR VENT THRU ROOF
- V SEWER VENT
- S SEWER LINE
- SOV SHUT-OFF VALVE
- FCO FLOOR CLEAN OUT
- WCO WALL CLEAN OUT
- IS ICE CREAM SCOOP SINK
- DS DUMP SINK

**KEYNOTES**

- 1 NEW SCH 40 ABS DRAIN LINE (TYP.)
- 2 AT 3-COMPARTMENT SINK AND PREPARATION SINK, PROVIDE 1-1/2" PVC DRAIN LINE FROM EACH SINK, DISCHARGE INDIRECTLY TO FLOOR SINK WITH 3" AIR GAP (TYP.)
- 3 3/4" SCH. 40 PVC DRAIN FROM EVAPORATOR TO FLOOR SINK WITH 1-1/2" AIRGAP.
- 4 AT DISHWASHER, PROVIDE 1-1/2" SCH. 40 PVC DRAIN TO DISCHARGE INDIRECTLY TO FLOOR SINK WITH 3" AIR GAP (TYP.)
- 5 NEW 80 GALLON GCS WATER HEATER
- 6 PROVIDE 3/4" Cu DRAIN LINES FROM T&P RELIEF VALVE AND TANK DRAIN VALVE, DISCHARGE INDIRECTLY TO MS-2 WITH 1-1/2" AIR GAP (TYP.)
- 7 NEW 1" TYPE "M" COPPER PIPE OVERFLOW DRAIN MAKE-UP AIR UNIT ON ROOFTOP, ROUTE BELOW ROOF AND DISCHARGE INDIRECTLY TO MOP SINK WITH 2" AIR GAP (TYP.)
- 8 PROVIDE 1000 GALLON GREASE INTERCEPTOR WITH TRAFFIC-RATED COVERS.

**GREASE INTERCEPTOR CALCULATIONS**

BY CITY OF MESA INTERCEPTOR/TRAP SIZING CALCULATION WORK SHEET:

FIXTURE	COUNT	SIZE	FIXTURE VALUE	TOTAL
3-COMP SINK	1	2"	3	3
PREP SINKS	1	2"	3	3
MOP SINK	2	2"	2	2
FLOOR DRAIN	5	2"	1	5
DUMP SINK	3	1-1/2"	1	3
DISHWASHER	1	1-1/2"	3	5
<b>TOTAL</b>				<b>21</b>

FORMULA:  
GREASE TRAP CAPACITY = (TOTAL FIXTURE COUNT \* FLOW RATE (GPM)) \* RETENTION TIME  
= (19 F.U. X 3 GPM X 12 HRS) = 756 GALLONS

PROVIDE 1000 GALLON GREASE INTERCEPTOR

NEW GREASE INTERCEPTOR SCHEDULE		
MANUFACTURER	MODEL	OPERATING CAPACITY/GAL
JENSEN PRECAST	CL1000ECE-G	1000 GALLONS

INSTALL PER MANUFACTURER'S RECOMMENDATIONS.

NOTE:  
CONTRACTOR SHALL OBTAIN APPROVAL OF GREASE INTERCEPTOR FROM CITY OF MESA PRIOR TO DIGGING.

PROJECT NO.: MRT2201  
DESIGNED BY: DG  
DRAWN BY: GB  
CHECKED BY: DG

NO.	REVISION	DATE

ENGINEERING SEAL  
  
 EXPIRES 03/31/22

**GARDEL** engineering  
 MECHANICAL & ELECTRICAL ENGINEERING  
 441 S. 48TH ST. SUITE 101  
 TEMPE, AZ 85281  
 OFFICE: (480)361-3667  
 MOBILE: (480)217-5853  
 WWW.GARDELENGINEERING.COM  
THE INFORMATION CONTAINED ON THESE DRAWINGS SUCH AS DATA, DESIGNS, AND CONCEPTS ARE PROPERTY OF GARDEL ENGINEERING, LLC AND SHALL NOT BE USED FOR ANY OTHER PURPOSE, OTHER THAN ORIGINALLY INTENDED WITHOUT WRITTEN PERMISSION OF THE ENGINEER.

DENNY'S RESTAURANT #9633  
 MESA NEW BUILD  
 4248 S SIGNAL BUTTE RD  
 MESA, AZ 85212

PROJECT:

**PLUMBING PLAN INDEX**

- P1 SEWER PLUMBING PLAN
- P2 SEWER ISOMETRIC DIAGRAM
- P3 WATER PLUMBING PLAN
- P4 GAS PLUMBING PLAN
- P5 PLUMBING DETAILS
- P6 PLUMBING SPECIFICATIONS AND SITE PLAN

SHEET #:  
**P1**  
 SHEET TITLE:  
 SEWER PLUMBING PLAN

NO.	REVISION	DATE

ENGINEERING SEAL



EXPIRES 03/31/22

**GARDEL**  
 engineering

MECHANICAL & ELECTRICAL  
 ENGINEERING

441 S. 48TH ST. SUITE 101  
 TEMPE, AZ 85281  
 OFFICE: (480)361-3667  
 MOBILE: (480)217-5853

WWW.GARDELENGINEERING.COM

THE INFORMATION CONTAINED ON THESE DRAWINGS SUCH AS DATA, DESIGNS, AND CONCEPTS ARE PROPERTY OF GARDEL ENGINEERING, LLC AND SHALL NOT BE USED FOR ANY OTHER PURPOSE. OTHER THAN ORIGINALLY INTENDED WITHOUT WRITTEN PERMISSION OF THE ENGINEER.

DENNY'S RESTAYRANT #9633  
 MESA NEW BUILD  
 4248 S SIGNAL BUTTE RD  
 MESA, AZ 85212

PROJECT:

SHEET #:  
**P3**  
 SHEET TITLE:  
 WATER PLUMBING PLAN

**KEYNOTES**

- 1 NEW 2" TYPE "K" COPPER MAIN WATER PIPE ROUTED UNDERGROUND FROM METER
- 2 PROVIDE 3/4" SOV AND VACUUM BREAKER VALVE FOR IRRIGATION SYSTEM
- 3 PROVIDE 3/4" HOSE BIBB WITH KEY ACCESS PANEL ON WALL AT +24 AFF (TYP.)
- 4 WATER FILTER MOUNTED ON WALL
- 5 WATER SOFTENER MOUNTED ON FLOOR
- 6 100 GALLON NATURAL GAS WATER HEATER MOUNTED ON BASE.
- 7 PROVIDE EXPANSION TANK
- 8 AUTOMATIC CIRCULATING PUMP CP-1
- 9 PIPE THRU ROOF (TYP.)
- 10 PROVIDE 1/2" SHUT-OFF VALVE AND CHECK VALVE AT MAKE UP AIR UNIT.
- 11 PROVIDE A NSF APPROVED BACK-FLOW PREVENTOR
- 12 NEW PEX HOT AND COLD WATER LINES ROUTED ABOVE CEILING.
- 13 1" FLUSH-OMETER MANUAL VALVE, INSTALL PER MANUFACTURE'S MANUAL.
- 14 1" MANUAL VALVE ABOVE CEILING
- 15 1" WATER HAMMER ARRESTOR VALVE ABOVE CEILING
- 16 PROVIDE VALVE ACCESS DOOR AT CEILING (TYP.)

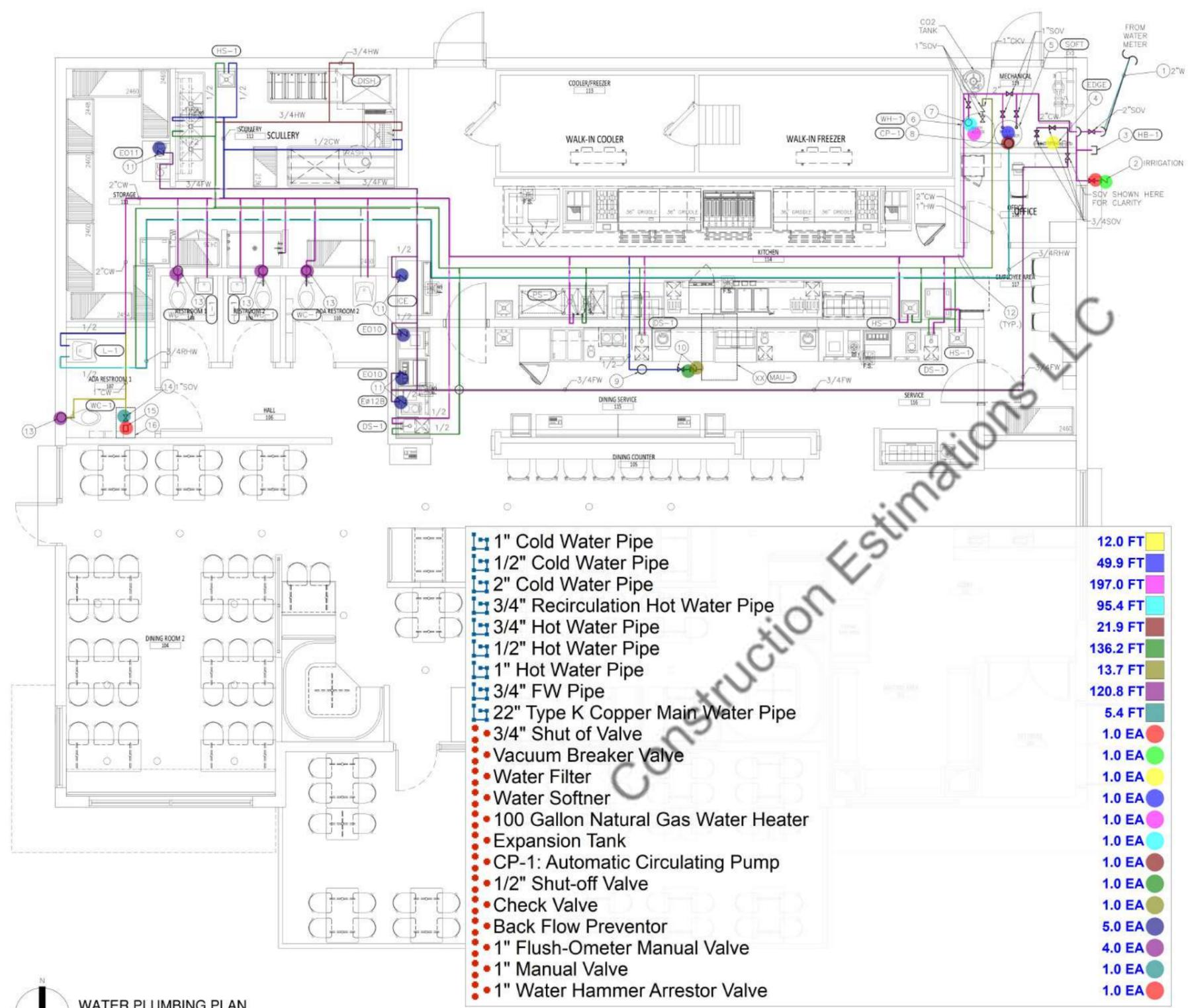

**WATER PLUMBING PLAN**  
 SCALE: 1/4" = 1'-0"

NO.	REVISION	DATE

ENGINEERING SEAL



**KEY NOTES**

- 1 NEW 2" GAS METER ON EXISTING GAS STUB-UP AND MANIFOLD
- 2 PROVIDE 2" FULL-PORT SHUT OFF VALVE
- 3 2-1/2" SCH 40 STEEL GAS LINE ON WALL
- 4 PIPE THRU WALL AT +12 AFF
- 5 NEW SCH. 40 GAS LINE ROUTED ABOVE CEILING
- 6 NEW 2" AUTOMATIC GAS SHUT-OFF VALVE ABOVE CEILING
- 7 GAS PIPE DOWN TO MANIFOLD
- 8 2" MANIFOLD AT +24" AFF
- 9 PROVIDE GAS COCK VALVE AND FLEX TUBING PER APPLIANCE'S INSTALLATION MANUAL
- 10 PROVIDE DIRT LEG (TYP.)
- 11 100 GALLON GAS WATER HEATER

**EQUIPMENT SCHEDULE AND GAS DEMAND**

EQUIPMENT ID	EQUIPMENT DESCRIPTION	MANUFACTURER MODEL	INPUT BTU/Hr	GAS TYPE	PRESSURE (W/C)	GAS IN (IN)	CONDITION
FRYER 1,2,3	GAS FRYER	BY OWNER	(3)x70,000 = 210,000	NATURAL	7"	3/4"	NEW
GRIDDLE 1,2,3,4	RICE COOKER	BY OWNER	(4)x90,000 = 360,000	NATURAL	7"	3/4"	NEW
WH-1	GAS WATER HEATER	RHEEM-ROUD 6100-8DN	76,000	NATURAL	7"	3/4"	NEW
RANGE 1,2	10 BURNER RANGE	BY OWNER	(2)x90,000 = 180,000	NATURAL	7"	3/4"	NEW
TOTAL BTU/HR			826,000				

PIPE CALCULATION  
 NATURAL GAS HEATING VALUE = 1,000 BTU/CF  
 CUBIC FEET REQUIRED =  $\frac{826,000 \text{ BTU/HR}}{1,000 \text{ BTU/CF}} = 826 \text{ CFH}$   
 NATURAL GAS PIPING CALCULATIONS (2018 IFGC)  
 DEVELOPED LENGTH OF PIPING TO REMOTE OUTLET = 88'  
 2018 IFGC TABLE 402.4(2) = DEMAND 1,205 CFH  
 PROVIDE 2" GAS PIPE AND METER.

**GAS PIPING SUPPORT**

VERTICAL	SUPPORT VERTICAL SECTIONS OF PIPING DIRECTLY TO WALL USING STEEL CLAMP. PROVIDE ONE SUPPORT AT EVERY FLOOR LEVEL (MIN.)	
	PIPE	SUPPORT SPACING
HORIZONTAL	1/2"	6'
	3/4" OR 1"	8'
	1-1/2" OR LARGER	10'

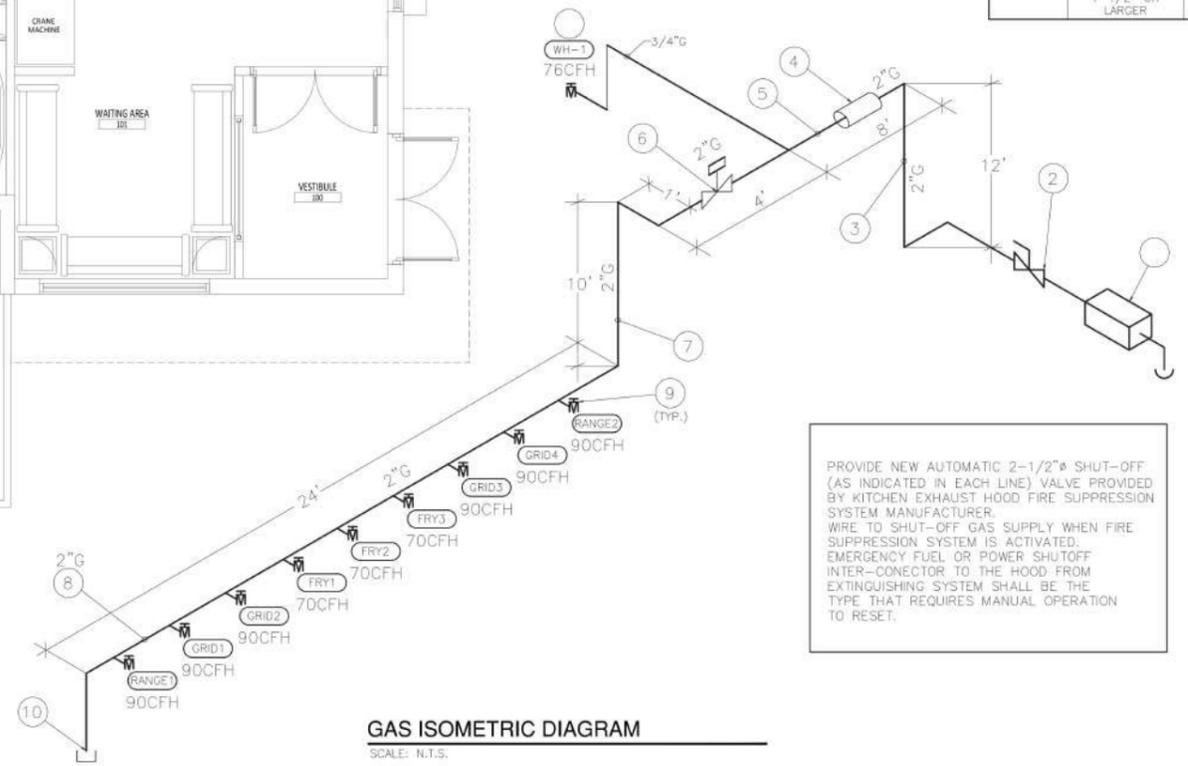
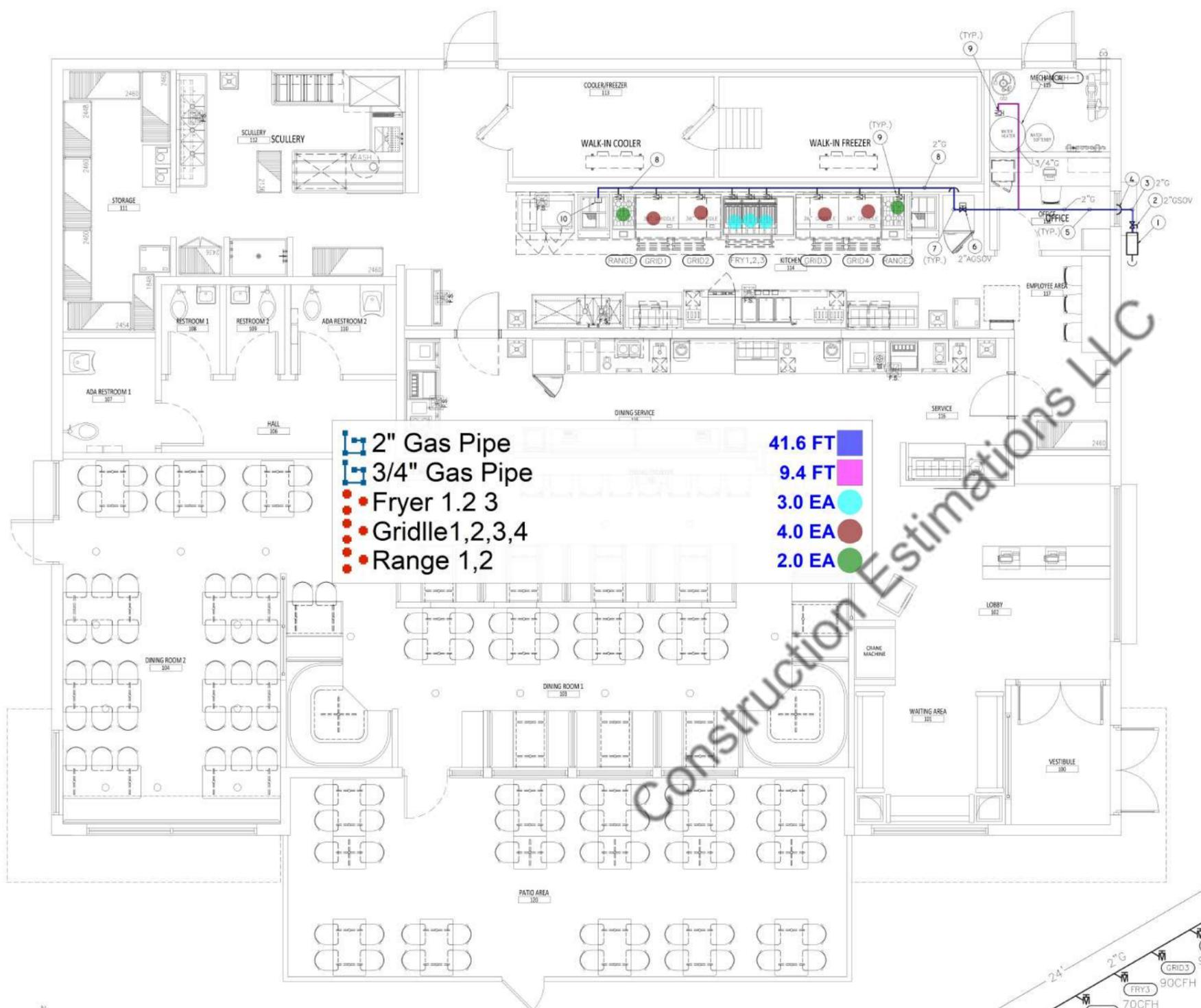

PROVIDE NEW AUTOMATIC 2-1/2" SHUT-OFF (AS INDICATED IN EACH LINE) VALVE PROVIDED BY KITCHEN EXHAUST HOOD FIRE SUPPRESSION SYSTEM MANUFACTURER. WIRE TO SHUT-OFF GAS SUPPLY WHEN FIRE SUPPRESSION SYSTEM IS ACTIVATED. EMERGENCY FUEL OR POWER SHUTOFF INTER-CONNECTOR TO THE HOOD FROM EXTINGUISHING SYSTEM SHALL BE THE TYPE THAT REQUIRES MANUAL OPERATION TO RESET.

**GAS PLUMBING PLAN**  
 SCALE: 1/4" = 1'-0"

Construction Estimations LLC

DENNY'S RESTAURANT #9633  
 MESA NEW BUILD  
 4248 S SIGNAL BUTTE RD  
 MESA, AZ 85212

PROJECT:

SHEET #:  
**P4**  
 SHEET TITLE:  
 GAS PLUMBING PLAN

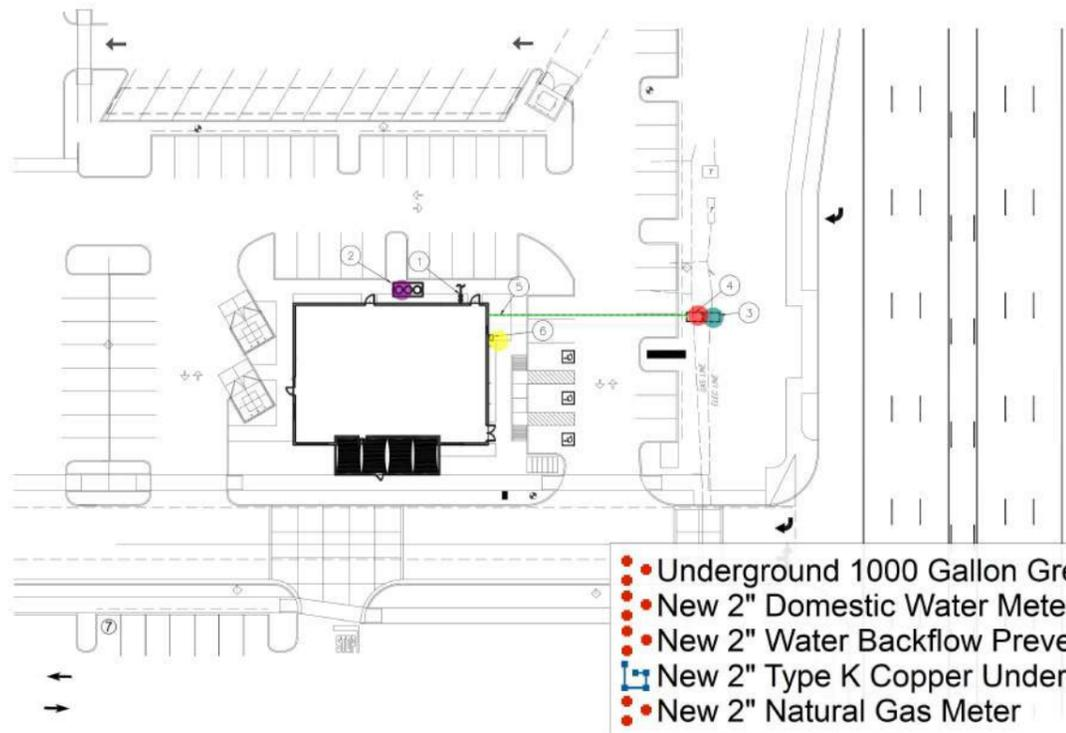

- 1.0 EA Underground 1000 Gallon Grease Interceptor
- 1.0 EA New 2" Domestic Water Meter
- 1.0 EA New 2" Water Backflow Preventor
- 9.8 FT New 2" Type K Copper Underground Main Water Line
- 1.0 EA New 2" Natural Gas Meter

## PLUMBING SPECIFICATIONS

**1. GENERAL**

1.1 Scope: Work under this section includes coordinating and furnishing all labor and material necessary to install a complete plumbing system as shown and specified and in accordance with the codes. Contractor shall pay for all permits, meters, fees, city inspections, legal notices, etc., as required.

1.2 Submittals: Within 15 days after award of contract, submit 8 copies of all items.

1.3 Record Drawings: Provide a set to the Architect at completion of project.

1.4 Instructions: Provide maintenance manual and instruct Owner in the proper operation and maintenance of the equipment.

1.5 Guarantee: One year on labor, material and equipment.

**2. PRODUCTS**

2.1 Piping:

2.1.1 Water Piping:

2.1.1.1 Copper: Type M for water pipe set in or under concrete or in the ground. Provide plastic sleeve for each piping penetration through concrete slab.

2.1.1.2 Fittings: Wrought copper conforming to ANSI B16.22.

2.1.1.3 Tubing: above and below grade, Type: Wirubo AQUAPEX Cross-linked polyethylene (PEX) manufactured by PEX-a or Engel method. Manufactured in accordance with ASTM F876 and ASTM F877 and tested for compliance by an independent third party agency. Standard Grade hydrostatic design and pressure ratings from PPL. Verify proposed installation is acceptable to Authority Having Jurisdiction prior to construction.

2.1.2 Sanitary Waste and Vent Piping:

2.1.2.1 Plastic: Subject to Owner approval, ABS plastic piping conforming to ASTM D-2751-88, Schedule 40, or PVC piping conforming to ASTM D2665-88, are acceptable for sanitary waste and vent piping. Fittings: Drainage fittings to match pipe.

2.3 Cleanouts

2.3.1 Concrete and Tile Floors: J.R. Smith 4023, with scoriated nickel-bronze top.

2.3.2 Surface Cleanouts: J.R. Smith 4253, concrete ring below grade at asphalt.

2.3.3 Sanitary Waste and Vent Cleanouts: J.R. Smith 4023, with scoriated nickel-bronze top.

2.3.4 Floor Drains: J.R. Smith 4023, with scoriated nickel-bronze top.

2.3.5 Floor Sinks: J.R. Smith 4023, with scoriated nickel-bronze top.

2.3.6 Floor Sinks: J.R. Smith 4023, with scoriated nickel-bronze top.

2.3.7 Floor Sinks: J.R. Smith 4023, with scoriated nickel-bronze top.

2.3.8 Floor Sinks: J.R. Smith 4023, with scoriated nickel-bronze top.

2.3.9 Floor Sinks: J.R. Smith 4023, with scoriated nickel-bronze top.

2.3.10 Floor Sinks: J.R. Smith 4023, with scoriated nickel-bronze top.

2.3.11 Floor Sinks: J.R. Smith 4023, with scoriated nickel-bronze top.

2.3.12 Floor Sinks: J.R. Smith 4023, with scoriated nickel-bronze top.

2.3.13 Floor Sinks: J.R. Smith 4023, with scoriated nickel-bronze top.

2.3.14 Floor Sinks: J.R. Smith 4023, with scoriated nickel-bronze top.

2.3.15 Floor Sinks: J.R. Smith 4023, with scoriated nickel-bronze top.

2.3.16 Floor Sinks: J.R. Smith 4023, with scoriated nickel-bronze top.

2.3.17 Floor Sinks: J.R. Smith 4023, with scoriated nickel-bronze top.

2.3.18 Floor Sinks: J.R. Smith 4023, with scoriated nickel-bronze top.

2.3.19 Floor Sinks: J.R. Smith 4023, with scoriated nickel-bronze top.

2.3.20 Floor Sinks: J.R. Smith 4023, with scoriated nickel-bronze top.

2.3.21 Floor Sinks: J.R. Smith 4023, with scoriated nickel-bronze top.

2.3.22 Floor Sinks: J.R. Smith 4023, with scoriated nickel-bronze top.

2.3.23 Floor Sinks: J.R. Smith 4023, with scoriated nickel-bronze top.

2.3.24 Floor Sinks: J.R. Smith 4023, with scoriated nickel-bronze top.

2.3.25 Floor Sinks: J.R. Smith 4023, with scoriated nickel-bronze top.

2.3.26 Floor Sinks: J.R. Smith 4023, with scoriated nickel-bronze top.

2.3.27 Floor Sinks: J.R. Smith 4023, with scoriated nickel-bronze top.

2.3.28 Floor Sinks: J.R. Smith 4023, with scoriated nickel-bronze top.

2.3.29 Floor Sinks: J.R. Smith 4023, with scoriated nickel-bronze top.

2.3.30 Floor Sinks: J.R. Smith 4023, with scoriated nickel-bronze top.

2.3.31 Floor Sinks: J.R. Smith 4023, with scoriated nickel-bronze top.

2.3.32 Floor Sinks: J.R. Smith 4023, with scoriated nickel-bronze top.

2.3.33 Floor Sinks: J.R. Smith 4023, with scoriated nickel-bronze top.

2.3.34 Floor Sinks: J.R. Smith 4023, with scoriated nickel-bronze top.

2.3.35 Floor Sinks: J.R. Smith 4023, with scoriated nickel-bronze top.

2.3.36 Floor Sinks: J.R. Smith 4023, with scoriated nickel-bronze top.

2.3.37 Floor Sinks: J.R. Smith 4023, with scoriated nickel-bronze top.

2.3.38 Floor Sinks: J.R. Smith 4023, with scoriated nickel-bronze top.

2.3.39 Floor Sinks: J.R. Smith 4023, with scoriated nickel-bronze top.

2.3.40 Floor Sinks: J.R. Smith 4023, with scoriated nickel-bronze top.

2.3.41 Floor Sinks: J.R. Smith 4023, with scoriated nickel-bronze top.

2.3.42 Floor Sinks: J.R. Smith 4023, with scoriated nickel-bronze top.

2.3.43 Floor Sinks: J.R. Smith 4023, with scoriated nickel-bronze top.

2.3.44 Floor Sinks: J.R. Smith 4023, with scoriated nickel-bronze top.

2.3.45 Floor Sinks: J.R. Smith 4023, with scoriated nickel-bronze top.

2.3.46 Floor Sinks: J.R. Smith 4023, with scoriated nickel-bronze top.

2.3.47 Floor Sinks: J.R. Smith 4023, with scoriated nickel-bronze top.

2.3.48 Floor Sinks: J.R. Smith 4023, with scoriated nickel-bronze top.

2.3.49 Floor Sinks: J.R. Smith 4023, with scoriated nickel-bronze top.

2.3.50 Floor Sinks: J.R. Smith 4023, with scoriated nickel-bronze top.

2.3.51 Floor Sinks: J.R. Smith 4023, with scoriated nickel-bronze top.

2.3.52 Floor Sinks: J.R. Smith 4023, with scoriated nickel-bronze top.

2.3.53 Floor Sinks: J.R. Smith 4023, with scoriated nickel-bronze top.

2.3.54 Floor Sinks: J.R. Smith 4023, with scoriated nickel-bronze top.

2.3.55 Floor Sinks: J.R. Smith 4023, with scoriated nickel-bronze top.

2.3.56 Floor Sinks: J.R. Smith 4023, with scoriated nickel-bronze top.

2.3.57 Floor Sinks: J.R. Smith 4023, with scoriated nickel-bronze top.

2.3.58 Floor Sinks: J.R. Smith 4023, with scoriated nickel-bronze top.

2.3.59 Floor Sinks: J.R. Smith 4023, with scoriated nickel-bronze top.

2.3.60 Floor Sinks: J.R. Smith 4023, with scoriated nickel-bronze top.

2.3.61 Floor Sinks: J.R. Smith 4023, with scoriated nickel-bronze top.

2.3.62 Floor Sinks: J.R. Smith 4023, with scoriated nickel-bronze top.

2.3.63 Floor Sinks: J.R. Smith 4023, with scoriated nickel-bronze top.

2.3.64 Floor Sinks: J.R. Smith 4023, with scoriated nickel-bronze top.

2.3.65 Floor Sinks: J.R. Smith 4023, with scoriated nickel-bronze top.

2.3.66 Floor Sinks: J.R. Smith 4023, with scoriated nickel-bronze top.

2.3.67 Floor Sinks: J.R. Smith 4023, with scoriated nickel-bronze top.

2.3.68 Floor Sinks: J.R. Smith 4023, with scoriated nickel-bronze top.

2.3.69 Floor Sinks: J.R. Smith 4023, with scoriated nickel-bronze top.

2.3.70 Floor Sinks: J.R. Smith 4023, with scoriated nickel-bronze top.

2.3.71 Floor Sinks: J.R. Smith 4023, with scoriated nickel-bronze top.

2.3.72 Floor Sinks: J.R. Smith 4023, with scoriated nickel-bronze top.

2.3.73 Floor Sinks: J.R. Smith 4023, with scoriated nickel-bronze top.

2.3.74 Floor Sinks: J.R. Smith 4023, with scoriated nickel-bronze top.

2.3.75 Floor Sinks: J.R. Smith 4023, with scoriated nickel-bronze top.

2.3.76 Floor Sinks: J.R. Smith 4023, with scoriated nickel-bronze top.

2.3.77 Floor Sinks: J.R. Smith 4023, with scoriated nickel-bronze top.

2.3.78 Floor Sinks: J.R. Smith 4023, with scoriated nickel-bronze top.

2.3.79 Floor Sinks: J.R. Smith 4023, with scoriated nickel-bronze top.

2.3.80 Floor Sinks: J.R. Smith 4023, with scoriated nickel-bronze top.

2.3.81 Floor Sinks: J.R. Smith 4023, with scoriated nickel-bronze top.

2.3.82 Floor Sinks: J.R. Smith 4023, with scoriated nickel-bronze top.

2.3.83 Floor Sinks: J.R. Smith 4023, with scoriated nickel-bronze top.

2.3.84 Floor Sinks: J.R. Smith 4023, with scoriated nickel-bronze top.

2.3.85 Floor Sinks: J.R. Smith 4023, with scoriated nickel-bronze top.

2.3.86 Floor Sinks: J.R. Smith 4023, with scoriated nickel-bronze top.

2.3.87 Floor Sinks: J.R. Smith 4023, with scoriated nickel-bronze top.

2.3.88 Floor Sinks: J.R. Smith 4023, with scoriated nickel-bronze top.

2.3.89 Floor Sinks: J.R. Smith 4023, with scoriated nickel-bronze top.

2.3.90 Floor Sinks: J.R. Smith 4023, with scoriated nickel-bronze top.

2.3.91 Floor Sinks: J.R. Smith 4023, with scoriated nickel-bronze top.

2.3.92 Floor Sinks: J.R. Smith 4023, with scoriated nickel-bronze top.

2.3.93 Floor Sinks: J.R. Smith 4023, with scoriated nickel-bronze top.

2.3.94 Floor Sinks: J.R. Smith 4023, with scoriated nickel-bronze top.

2.3.95 Floor Sinks: J.R. Smith 4023, with scoriated nickel-bronze top.

2.3.96 Floor Sinks: J.R. Smith 4023, with scoriated nickel-bronze top.

2.3.97 Floor Sinks: J.R. Smith 4023, with scoriated nickel-bronze top.

2.3.98 Floor Sinks: J.R. Smith 4023, with scoriated nickel-bronze top.

2.3.99 Floor Sinks: J.R. Smith 4023, with scoriated nickel-bronze top.

2.3.100 Floor Sinks: J.R. Smith 4023, with scoriated nickel-bronze top.

2.6 Pipe Identification:

2.6.1 Mark soft water piping systems with Brady, Seton, Brimar or Set Mark identification markers of snap-on type after pipe has been painted or insulated where exposed.

2.6.2 Install stencils at all major branch takeoffs, risers and at 10-foot intervals on straight runs and at each entrance or exit from pipe shafts. Markers shall be located for maximum visibility from expected approach.

2.6.3 Identification material sizes shall be as follows:

2" and under 1/2" high letters  
Over 2" 1" high letters

2.7 Acceptable Manufacturers: The following is a list of manufacturers whose equipment is acceptable as to manufacturer, subject to conformance with all drawings, specifications and addenda items:

Water Heaters: Rheem, American, A. O. Smith, State, Eemax, Hot Aqua, Rinnai.

Valves: Crane, Kennedy, Stockham, Grinnell, Milwaukee, Wolverine.

Hose Bibbs: Acorn, Chicago, Woodford.

Supplies, Stops: Eastman, Kohler, Eljer, Brasscraft, McGuire.

P-Traps: Crane, Kohler, Eljer, Frost, McGuire.

Drains and Cleanouts: J. R. Smith, Zurn, Jozam, Wade, Western.

Hangers: Grinnell, Fee & Mason, Eichen, Kin-Line, F & S, B-Line, Michigan.

**3. EXECUTION**

3.1 Tests and Inspections:

3.1.1 All work to be tested and approved before covering as directed by building official to ensure compliance with requirements of code. Retest all leaking joints and retest.

3.1.2 Potable Water Systems: 150 psi hydrostatic pressure held without loss for four hours.

3.1.3 Sanitary Waste and Vent System: Fill with water to highest point in the system and let stand without loss for two hours.

3.1.4 Sterilization (Domestic Water System): After tests have been completed, the entire domestic water distribution system shall be thoroughly flushed with water until all entrained dirt and mud have been removed, and shall be sterilized with solutions of either liquid chlorine conforming to Federal Specification BB-B-120 or hypochlorite conforming to Fed. Spec. O-C-114, Type II, Grade G, or Fed. Spec. D-5-602, Grade A or B. The chlorinating material shall provide a dosage of not less than 50 parts per million and shall be introduced into the system in an approved manner, and retained in the system for 8 hours before flushing.

3.2 Flashing, Sleeves and Escutcheon Plates:

3.2.1 Flashing: Supply flashing for all vent pipe and other types of piping through roof to be installed with roofing. Flash vents with Stoneman 51300-4 or with sheet lead weighing not less than 4 pounds per square foot or equal. Extend flashing into roofing at least 10" from vent and turn flashing over and down into vent opening.

3.2.2 Sleeves: Use 20 gauge galvanized steel sleeves around pipes passing through masonry walls and concrete slabs.

3.2.3 Escutcheon Plates: Install cast brass split ring with setscrew at all locations where exposed pipes pass through walls, floors and/or ceilings. Provide polished chrome-plated escutcheons in finished rooms, all others polished brass.

3.3 Underground Water Piping: Bury all underground water piping a minimum of 24" below finished grade. Install copper lines below concrete floors so that no joints occur below floor and wrap with 20 mils of polyethylene tape with a minimum of 50% overlap.

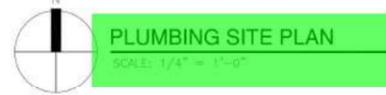

## PLUMBING SITE PLAN

SCALE: 1/4" = 1'-0"

## KEYNOTES

- 1 4" SCH 40 ABS MAIN SEWER LINE FROM BUILDING TO NEW SEWER TAP PER CIVIL PLANS.
- 2 UNDERGROUND 1000 GALLON GREASE INTERCEPTOR WITH TRAFFIC-RATED COVERS.
- 3 NEW 2" DOMESTIC WATER METER BY OTHERS, COORDINATE WITH CIVIL PLANS FOR EXACT LOCATION.
- 4 NEW 2" WATER BACK FLOW PREVENTOR PER CITY OF MESA REQUIREMENTS.
- 5 NEW 2" TYPE "K" COPPER UNDERGROUND MAIN WATER LINE TO BUILDING, ROUTED AT -36" BELOW GRADE.
- 6 NEW 2" NATURAL GAS METER AT SIDEWALK (TYP.)

## WATER HEATER IECC NOTES:

- A) MINIMUM EFFICIENCY FOR THIS WATER HEATER SHALL BE 92%.
- B) W.H. SHALL BE EQUIPPED WITH A TEMPERATURE CONTROL TO ALLOW A SET POINT LIMITED TO 90°F.
- C) PROVIDE 1" PIPE INSULATION FOR THE FIRST 6" EACH SIDE OF THE WATER HEATER.
- \*LIMITATION OF HOT WATER TEMPERATURE FOR PUBLIC LAVATORIES WILL BE PROVIDED. THE WATER HEATER THERMOSTAT SHALL NOT BE CONSIDERED A CONTROL FOR MEETING THIS PROVISION\*

## GAS WATER HEATER

ID NUMBER	DESCRIPTION	MANUFACTURER/MODEL	FITTINGS ACCESSORIES	V/PH	ROUGH-IN VENT	ROUGH-IN CW	ROUGH-IN HW	TANK CAPACITY	NAT. GAS INPUT BTUH	THERMAL EFFICIENCY
WH-1	GAS WATER HEATER	RHEEM-RUUD XG100-80N OR EQUAL	HEAT TRAP	120VAC	4"	1"	1"	100 GALLONS	75,000	92%

## PLUMBING FIXTURE SCHEDULE

FIXTURE NUMBER	DESCRIPTION	MANUFACTURER/MODEL	FITTINGS ACCESSORIES	ROUGH-IN			SIZE TRAP	MAXIMUM FLOW	REMARKS
				WASTE	VENT	CW			
MS-2	MOP SINK	BY FOOD SERVICE PLANS	BY OWNER	1-1/4"	1-1/2"	1/2"	1-1/4"	0.5 GPM	1
PS-1	PREP SINK	BY FOOD SERVICE PLANS	BY OWNER	2"	1-1/2"	1/2"	1-1/2"	0.5 GPM	
FS-1	FLOOR SINK	BY FOOD SERVICE PLANS	BY CONTRACTOR	2"	1-1/2"	-	1-1/2"	-	1
FD-1	FLOOR DRAIN	BY FOOD SERVICE PLANS	BY CONTRACTOR	2"	1-1/2"	-	1-1/2"	-	1
3CS-1	3 COMPARTMENT SINK	BY FOOD SERVICE PLANS	BY OWNER	1-1/2"	1-1/2"	1/2"	1-1/2"	2.2 GPM	1
HS-1	HAND SINK	BY FOOD SERVICE PLANS	BY OWNER	1-1/2"	1-1/2"	1/2"	1-1/2"	0.5 GPM	1
DS-1	DUMP SINK	BY FOOD SERVICE PLANS	BY OWNER	1-1/2"	1-1/2"	1/2"	1-1/2"	0.5 GPM	1
WC-1	WATER CLOSET	AMERICAN STANDARD CADET ELONGATED TOILET MODEL NO. P-368.012 (TYP.)	MANUAL FLUSHMETER VALVE	4"	2"	1"	4"	1.28 GPM	1
L-1	LAVATORY	BY CONTRACTOR	BY CONTRACTOR	1-1/4"	1-1/2"	1/2"	1-1/4"	0.5 GPM	1

BUILDING WATER AND SEWER DEMAND CALCULATIONS					
MAXIMUM PROBABLE DRAINAGE			DOMESTIC WATER SUPPLY DEMAND		
FIXTURE	QUANT.	WASTE F.U.	WASTE TOTAL	COLD WATER F.U.	WATER TOTAL
NEW WATER CLOSET	4	6	12	5	20
NEW RESTROOM LAVATORY	4	2	8	2	8
NEW MOP SINK	1	3	3	3	3
NEW 3 COMPARTMENT SINK	1	6	6	6	6
NEW HAND SINK	5	2	10	2	10
NEW PREP SINK	1	2	2	2	2
NEW DUMP SINK	3	2	6	2	6
NEW DISHWASHER	1	3	3	6	6
NEW FLOOR SINK & FLOOR DRAIN	9	1	9	0	0
NEW MAKEUP AIR UNIT	1	0	0	1	1
NEW HOSE BIBB	1	0	0	1	1
NEW IRRIGATION SYSTEM	1	0	0	2	2
TOTAL FU=		103		65	

EXISTING 4" DRAINAGE PIPING IS RATED FOR THIS PROJECT. TOTAL DEMAND= 55 GPM FLUSHMETER VALVES

DOMESTIC WATER CALCULATION (BUILDING)	
LINE PRESSURE 70 PSI (FIELD READING)	
HORIZONTAL PIPE LENGTH, METER TO LAST FIXTURE	240 FT
VERTICAL RISE TAP TO HIGHEST FIXTURE	10 FT
TOTAL LENGTH PIPE	250 FT
FEET LOSS (STATIC) FITTING LOSS 10%	25 FT
TOTAL EQUIVALENT LENGTH	275 FT
TOTAL FIXTURE UNITS:	65 FU
FLOW LOAD DEMAND:	55 GPM
PRESSURE LOSS:	
STREET PRESSURE (ASSUMED)*	70 PSI
NEW 2" TAP	4 PSI
NEW 1" METER	4 PSI
NEW 2" BACKFLOW PREVENTOR	4 PSI
STATIC HEIGHT (10X.5)	5 PSI
MINIMUM REQUIRED PRESSURE	30 PSI
TOTAL LOSS	47 PSI
AVAILABLE PRESSURE FOR PIPING LOSSES	23 PSI
23 PSI/275 FT x 100 = 8.36 MAX ALLOWABLE PSI DROP PER 100 FT	
EXISTING 1" WATER METER AND MAIN LINE ARE RATED FOR THIS PROJECT	

PROJECT NO.: MRT2201  
DESIGNED BY: DG  
DRAWN BY: GB  
CHECKED BY: DG

NO.	REVISION	DATE

ENGINEERING SEAL



EXPIRES 03/31/22

**GARDEL**  
engineering

MECHANICAL & ELECTRICAL ENGINEERING

441 S. 48TH ST. SUITE 101  
TEMPE, AZ 85281  
OFFICE: (480)361-3667  
MOBILE: (480)217-5853

WWW.GARDELENGINEERING.COM

THE INFORMATION CONTAINED ON THESE DRAWINGS SUCH AS DATA, DESIGNS, AND CONCEPTS ARE PROPERTY OF GARDEL ENGINEERING, LLC AND SHALL NOT BE USED FOR ANY OTHER PURPOSE OTHER THAN ORIGINALLY INTENDED WITHOUT WRITTEN PERMISSION OF THE ENGINEER.

DENNY'S RESTAURANT #9633  
MESA NEW BUILD  
4248 S SIGNAL BUTTE RD  
MESA, AZ 85212

PROJECT:

SHEET #:

**P6**

SHEET TITLE:  
PLUMBING SPECIFICATIONS AND SITE PLAN

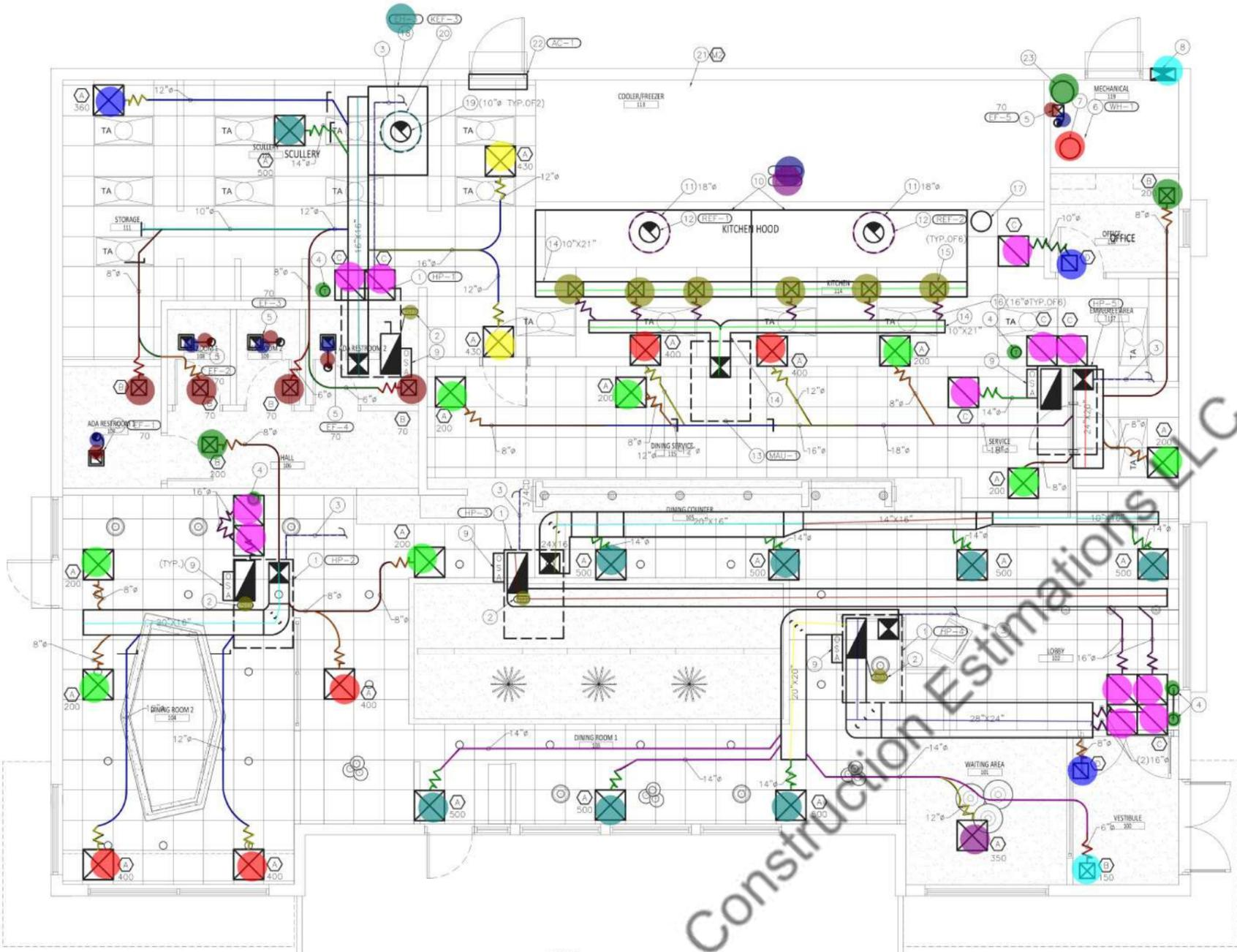

Some Of The Fixtures Covered On Rooftop Plan

**KEYNOTES**

- 1 5-TON HEAT PUMP ROOFTOP UNIT ON ROOFTOP
- 2 NEW DUCT SMOKE DETECTOR. PROVIDED WITH AUDIBLE AND VISIBLE SUPERVISION SIGNAL ON CEILING
- 3 3/4" SCH 40 PVC CONDENSATE DRAIN ROUTED ABOVE CEILING TO MOP SINK. DISCHARGE WITH 1-1/2" AIR GAP (TYP.)
- 4 7-DAY PROGRAMMABLE THERMOSTAT (TYP.)
- 5 CEILING EXHAUST FAN PROVIDE WITH BACK-DRAFT DAMPER AND VENT THRU ROOFTOP
- 6 GAS WATER HEATER
- 7 PROVIDE 4" TYPE "B" FLUE VENT THROUGH ROOF (TYP.)
- 8 PROVIDE COMBUSTION AND DILUTION AIR INTAKE THROUGH ROOF. ROUTE IT TO WATER HEATER ROOM WITH (2) 12"x12" GRILLES, ONE AT 12" A.F.F. AND ONE AT 12" BELOW CEILING
- 9 ADJUST OUTSIDE AIR AS NOTED ON M3
- 10 TYPE I KITCHEN EXHAUST HOOD, SEE DETAILS AND SPECS
- 11 GREASE DUCT FROM HOOD TO EXHAUST FAN
- 12 UP-BLAST EXHAUST FAN MOUNTED ON ROOF. SEE DETAILS AND SPECIFICATIONS
- 13 MAKE-UP AIR UNIT MOUNTED ON ROOFTOP. LATER LOCK WITH EXHAUST FANS, SEE ELECTRICAL PLANS
- 14 MAKE UP AIR SUPPLY AIR DUCT ROUTED ABOVE CEILING
- 15 MAKE UP AIR SUPPLY AIR BUILT-IN REGISTERS IN HOOD
- 16 MAKE UP SUPPLY AIR FLEX DUCT AND TAMPER, ADJUST AIRFLOW AS NOTED
- 17 KITCHEN HOOD'S FIRE PROTECTION SYSTEM BY OTHERS ON SEPARATED PERMIT
- 18 TYPE II EXHAUST HOOD
- 19 EXHAUST DUCT THROUGH ROOF
- 20 UP-BLAST FAN ON ROOFTOP SERVING EH-3
- 21 SEE M2 FOR REFRIGERATION MECHANICAL PLAN
- 22 AUTOMATIC AIR CURTAIN ABOVE DOOR (TYP.)
- 23 BULK CO2 TANK ON FLOOR.

- 12" Dia Supply Air Duct
- 14" Dia Supply Air Duct
- 10" Dia Supply Air Duct
- 8" Dia Supply Air Duct
- 6" Dia Supply Air Duct
- 16" Dia Supply Air Duct
- 18" Dia Supply Air Duct
- 16" Dia Flexible Duct
- 8" Dia Flexible Duct
- 6" Dia Flexible Duct
- 14" Dia Flexible Duct
- 12" Dia Flexible Duct
- 10" Dia Flexible Duct
- 10" x 21" Supply Air Duct
- 10" x 16" Supply Air Duct
- 14" x 16" Supply Air Duct
- 20" x 16" Supply Air Duct
- 24" x 16" Supply Air Duct
- 28" x 24" Supply Air Duct
- 20" x 20" Supply Air Duct
- 16" x 16" Supply Air Duct
- 24" x 20" Supply Air Duct
- Thermostat
- Smoke Detector
- EF-1,2,3,4,5: Ceiling Exhaust Fan
- A: Supply Air Ceiling Register (CFM=350)
- A: Supply Air Ceiling Register (CFM=500)
- A: Supply Air Ceiling Register (CFM=400)
- A: Supply Air Ceiling Register (CFM=200)
- A: Supply Air Ceiling Register (CFM=430)
- A: Supply Air Ceiling Register (CFM=360)
- C: Return Air Transfer Grille
- B: Supply Air Ceiling Register (150 CFM)
- B: Supply Air Ceiling Register (70 CFM)
- B: Supply Air Ceiling Register (200 CFM)
- Supply Air Built In Register
- 3/4" PVC Condensate Drain
- 18" Dia Grease Duct
- 10" Dia Exhaust Duct
- 4" Dia New Type B Flue Vent
- D: Supply Air Ceiling Register
- Back Draft Damper
- Bulk CO2 Tank On Floor
- EH-1: Kitchen Exhaust Hood
- EH-2: Kitchen Exhaust Hood
- EH-3: Kitchen Exhaust Hood
- Combustion & Dillution Air Intake

MECHANICAL PLAN  
SCALE: 1/4" = 1'-0"

PROJECT NO.: MRT2201  
DESIGNED BY: DG  
DRAWN BY: GB  
CHECKED BY: DG

NO.	REVISION	DATE

ENGINEERING SEAL  
50667 DAVID GARCIA-ACOSTA  
EXPIRES 03/31/22

**GARDEL** engineering  
MECHANICAL & ELECTRICAL ENGINEERING  
441 S. 48TH ST. SUITE 101  
TEMPE, AZ 85281  
OFFICE: (480)361-3667  
MOBILE: (480)217-5853  
WWW.GARDELENGINEERING.COM  
THE INFORMATION CONTAINED ON THESE DRAWINGS SUCH AS DATA, DESIGNS, AND CONCEPTS ARE PROPERTY OF GARDEL ENGINEERING, LLC AND SHALL NOT BE USED FOR ANY OTHER PURPOSE OTHER THAN ORIGINALLY INTENDED WITHOUT WRITTEN PERMISSION OF THE ENGINEER.

DENNY'S RESTAYRANT #9633  
MESA NEW BUILD  
4248 S SIGNAL BUTTE RD  
MESA, AZ 85212

PROJECT:

SHEET #:  
**M2**  
SHEET TITLE:  
MECHANICAL PLAN

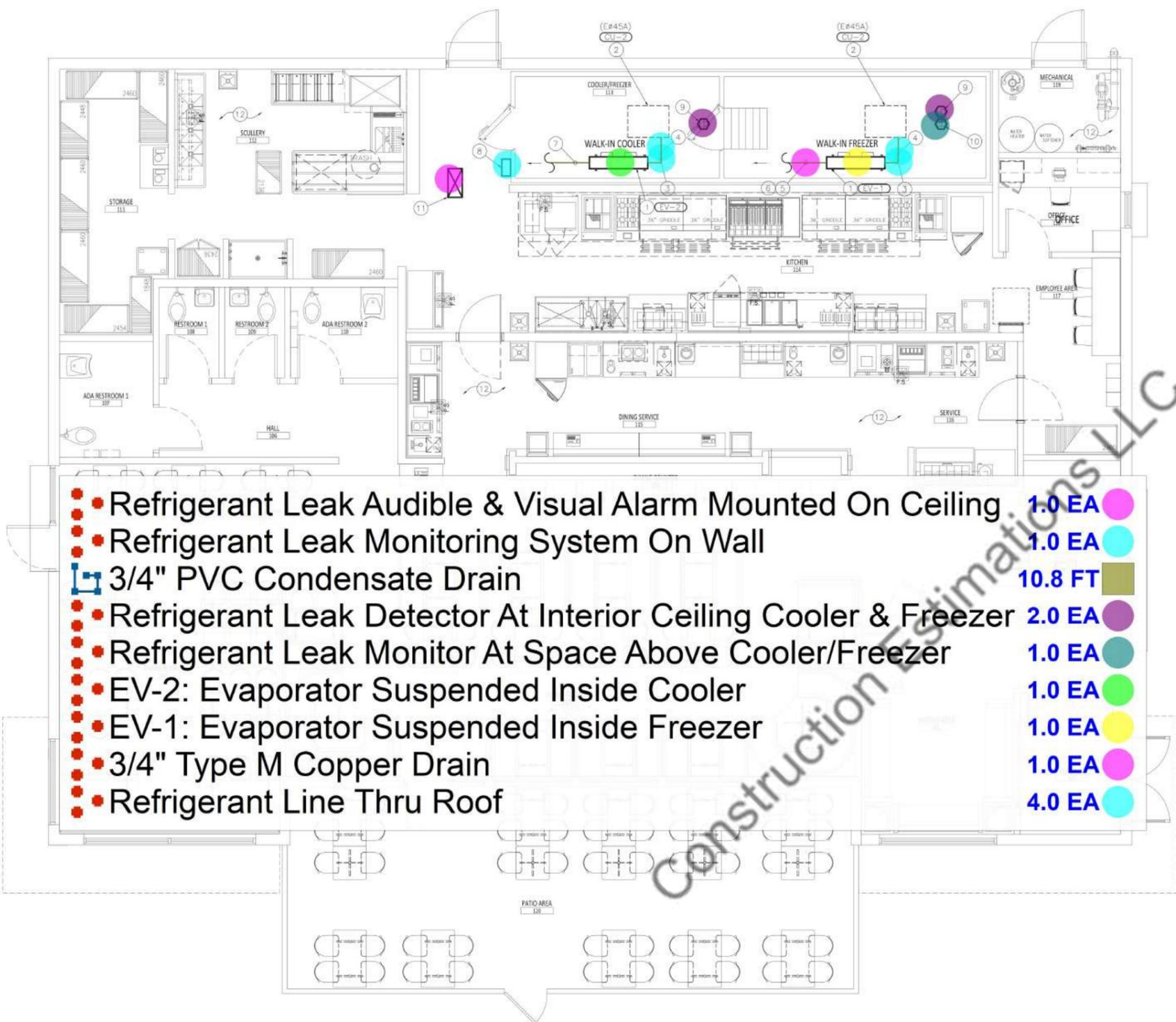

- Refrigerant Leak Audible & Visual Alarm Mounted On Ceiling 1.0 EA
- Refrigerant Leak Monitoring System On Wall 1.0 EA
- 3/4" PVC Condensate Drain 10.8 FT
- Refrigerant Leak Detector At Interior Ceiling Cooler & Freezer 2.0 EA
- Refrigerant Leak Monitor At Space Above Cooler/Freezer 1.0 EA
- EV-2: Evaporator Suspended Inside Cooler 1.0 EA
- EV-1: Evaporator Suspended Inside Freezer 1.0 EA
- 3/4" Type M Copper Drain 1.0 EA
- Refrigerant Line Thru Roof 4.0 EA

**KEYNOTES**

- 1 EVAPORATOR SUSPENDED INSIDE COOLER/FREEZER
- 2 CONDENSING UNIT MOUNTED ON ROOFTOP
- 3 FIELD-INSTALL REFRIGERANT LINE SET
- 4 REFRIGERANT LINE SET THRU COOLER'S ROOF AND THRU BUILDING'S ROOF. SEAL ALL PENETRATIONS
- 5 3/4" TYPE "M" COPPER DRAIN PIPE SLOPED TO DISCHARGE TO FLOOR SINK, SEE MECHANICAL PLANS
- 6 PROVIDE 1" FIBERGLASS INSULATION ON PIPE AND HEATHER TAPE.
- 7 3/4" SCH. 40 PVC CONDENSATE DRAIN TO FLOOR SINK, SEE MECHANICAL PLANS.
- 8 PROVIDE REFRIGERANT LEAK MONITORING SYSTEM ON WALL
- 9 PROVIDE REFRIGERANT LEAK DETECTOR AT INTERIOR CEILING OF COOLER AND FREEZER.
- 10 PROVIDE REFRIGERANT LEAK MONITOR AT SPACE ABOVE COOLER / FREEZER
- 11 PROVIDE REFRIGERANT LEAK AUDIBLE AND VISUAL ALARM MOUNTED ON CEILING.
- 12 NO WORK IN THIS AREA U.N.O

**SEQUENCE OF OPERATION OF REFRIGERANT MONITORING SYSTEM**

1. AT THE DETECTION OF REFRIGERANT BY THE PROPOSED SENSORS "LD", THE MONITORING SYSTEM WILL ACTIVATE ALARM
2. ALARM IS ANNUNCIATES LEAK BY VISUAL AND SOUND SIGNALS THAT REMAIN ACTIVE UNTIL LEAK IS CLEARED.
3. SEE PAGE M6 FOR MORE DETAIL AND SPECIFICATIONS OF MONITORING SY

**REFRIGERANT PIPE MATERIAL NOTES**

- 1107.5.1 Steel Pipe**  
Carbon steel pipe with a wall thickness not less than Schedule 80 shall be used for Group A2, A3, B2 or B3 refrigerant liquid lines for sizes 1.5 inches (38 mm) and smaller. Carbon steel pipe with a wall thickness not less than Schedule 40 shall be used for Group A1 or B1 refrigerant liquid lines 6 inches (152 mm) and smaller. Group A2, A3, B2 or B3 refrigerant liquid lines sizes 2 inches (51 mm) through 6 inches (152 mm) and all refrigerant suction and discharge lines 6 inches (152 mm) and smaller. Type F steel pipe shall not be used for refrigerant lines having an operating temperature less than -20°F (-29°C).
- 1107.5.2 Copper and Copper-Alloy Pipe**  
Standard iron-pipe size, copper and copper-alloy (not less than 80-percent copper) pipe shall conform to ASTM B42 and ASTM B43.
- 1107.5.3 Copper Tube**  
Copper tube used for refrigerant piping erected on the premises shall be seamless copper tube of Type ACR (hard or annealed) complying with ASTM B280 or ASTM B819. Annealed temper copper tube shall not be used in sizes larger than a 2-inch (51 mm) nominal size. Mechanical joints other than press-connect joints listed for refrigerant piping shall not be used on annealed temper copper tube in sizes larger than 7/8-inch (22.2 mm) OD size.
- 1107.5.4 Copper Tubing Joints**  
Copper tubing joints used in refrigerating systems containing Group A2, A3, B2 or B3 refrigerants shall be brazed. Soldered joints shall not be used in such refrigerating systems.
- 1107.5.5 Aluminum Tube**  
Type 3003-O aluminum tubing with high-pressure fittings shall not be used with methyl chloride and other refrigerants known to attack aluminum.

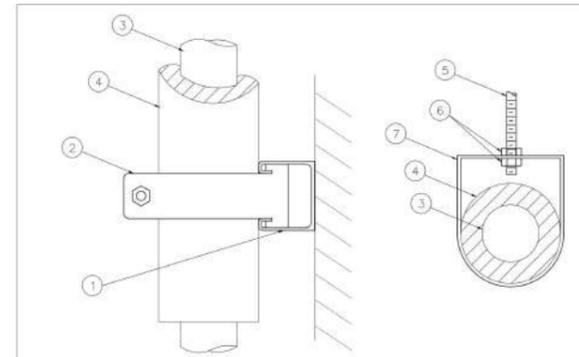

**REFRIGERANT PIPE SUPPORTS**

SCALE: N.T.S.

**KEYNOTES**

- 1 UNISTRUT CHANNEL BOLTED TO COOLER OR BUILDING STRUCTURE
- 2 UNISTRUT CLAMP
- 3 REFRIGERANT COPPER TUBING
- 4 1" ARMACELL INSULATION
- 5 1/2" Ø GALVANIZED STEEL ALL-THREADED ROD SUSPENDED FROM STRUCTURE (TYP.)
- 6 1/2" NUT AND WASHER ON EACH SIDE
- 7 GALVANIZED CLEVIS ANVIL PIPE HANGER

**MECHANICAL REFRIGERANT PLAN**  
SCALE: 1/4" = 1'-0"

PROJECT NO.: MRT2201  
DESIGNED BY: DG  
DRAWN BY: GB  
CHECKED BY: DG

NO.	REVISION	DATE

ENGINEERING SEAL



**GARDEL**  
engineering

MECHANICAL & ELECTRICAL ENGINEERING

441 S. 48TH ST. SUITE 101  
TEMPE, AZ 85281  
OFFICE: (480)361-3667  
MOBILE: (480)217-5853

WWW.GARDELENGINEERING.COM

THE INFORMATION CONTAINED ON THESE DRAWINGS SUCH AS DATA, DESIGNS, AND CONCEPTS, ARE PROPERTY OF GARDEL ENGINEERING, LLC AND SHALL NOT BE USED FOR ANY OTHER PURPOSE OTHER THAN ORIGINALLY INTENDED WITHOUT WRITTEN PERMISSION OF THE ENGINEER.

DENNY'S RESTAYRANT #9633  
MESA NEW BUILD  
4248 S SIGNAL BUTTE RD  
MESA, AZ 85212

PROJECT:

SHEET #:  
**M3**  
SHEET TITLE:  
MECHANICAL REFRIGERANT PLAN

NO.	REVISION	DATE

ENGINEERING SEAL



EXPIRES 03/31/22

**Mechanical & Electrical Engineering**

441 S. 48TH ST. SUITE 101  
 TEMPE, AZ 85281  
 OFFICE: (480)361-3667  
 MOBILE: (480)217-5853

WWW.GARDELENGINEERING.COM

THE INFORMATION CONTAINED ON THESE DRAWINGS SUCH AS DATA, DESIGNS, AND CONCEPTS, ARE PROPERTY OF GARDEL ENGINEERING, LLC, AND SHALL NOT BE USED FOR ANY OTHER PURPOSE, OTHER THAN ORIGINALLY INTENDED WITHOUT WRITTEN PERMISSION OF THE ENGINEER.

DENNY'S RESTAYRANT #9633  
 MESA NEW BUILD  
 4248 S SIGNAL BUTTE RD  
 MESA, AZ 85212

PROJECT:

SHEET #:  
**M4**  
 SHEET TITLE:  
 MECHANICAL ROOFTOP PLAN

**KEYNOTES**

- 1 NEW 5-TON HEAT PUMP PACKAGE UNIT ON ROOFTOP
- 2 NEW RESTROOM EXHAUST FAN VENT
- 3 NEW SEWER VENT THROUGH ROOF
- 4 NEW TYPE "B" FLUE VENT THRU ROOF
- 5 NEW UP-BLAST EXHAUST FAN MOUNTED ON ROOFTOP
- 6 NEW MAKEUP AIR UNIT MOUNTED ON ROOFTOP
- 7 AT AC UNIT, PROVIDE A NEW OUTSIDE AIR (OSA) INTAKE WITH SCREEN AND DAMPER, ADJUST AIRFLOW AS NOTED
- 8 WALK-IN FREEZER'S CONDENSING UNIT W<100 LBS
- 9 WALK-IN COOLER'S CONDENSING UNIT W<100 LBS
- 10 ROOF ACCESS LADDER AND HATCH.

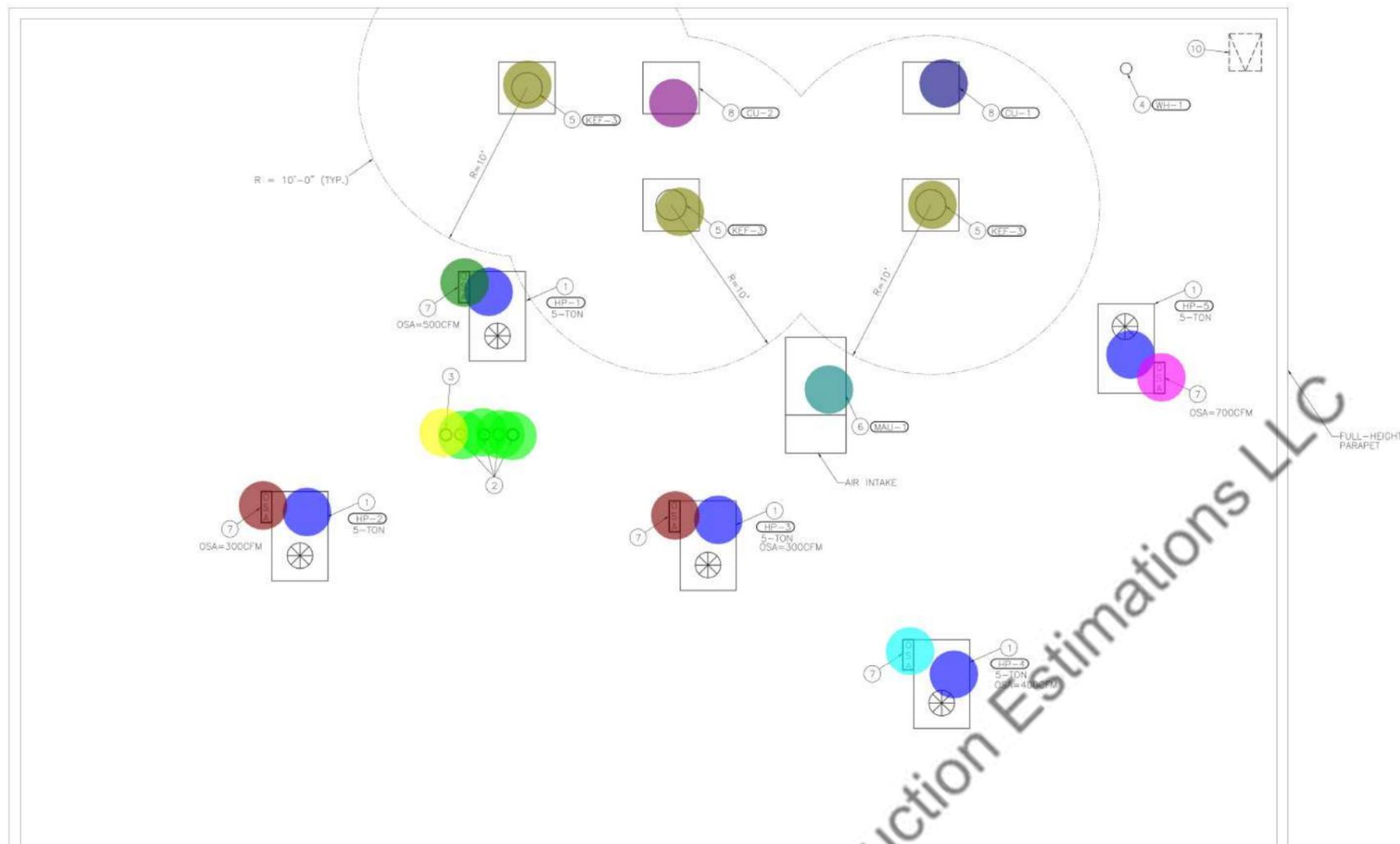

- New 5-Ton Heat Pump Package Unit: HP-1,2,3,4,5 5.0 EA
- New Outside Air(OSA) Intake With Screen & Damper (7000 CFM) 1.0 EA
- New Outside Air(OSA) Intake With Screen & Damper (4000 CFM) 1.0 EA
- New Outside Air(OSA) Intake With Screen & Damper (3000 CFM) 2.0 EA
- New Outside Air(OSA) Intake With Screen & Damper (500 CFM) 1.0 EA
- KEF-3: New Up-Blast Exhaust Fan 3.0 EA
- CU-1: Walk In Freezer Condensing Unit 1.0 EA
- CU-2: Walk In Freezer Condensing Unit 1.0 EA
- MAU-1: New Makeup Air Unit 1.0 EA
- New Restroom Exhaust Fan Vent 4.0 EA
- New Sewer Vent 1.0 EA

**MECHANICAL ROOFTOP PLAN**  
 SCALE: 1/4" = 1'-0"

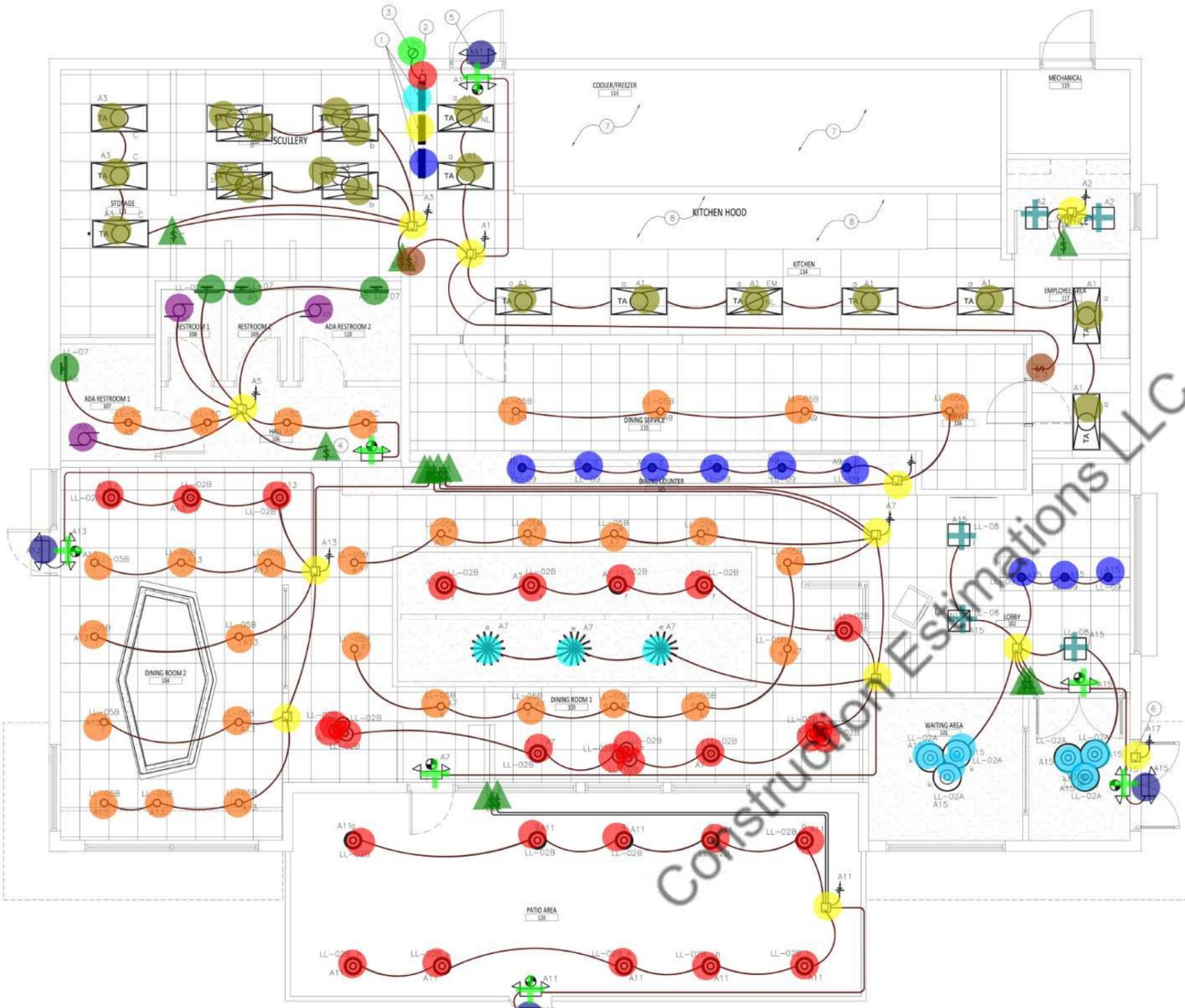

**ELECTRICAL LIGHTING PLAN**  
SCALE: 1/4" = 1'-0"

- Electrical Wiring
- TA: 2' x 4' Grid Light Fixture
- Emergency Light
- Emergency Light With Exit Sign
- LL-08: Low Profile 12" x 12" Square Light
- LL-02B: 24" Drum Pendant Light
- LL-02A: LED Suspended Light
- LL-09: 6" Eye Ball Fixture Light
- LL-05B/05C: 6" White Recessed Round Light
- Junction Box
- Toggle Switch- Single Way
- Toggle Switch- Three Way
- Weather Fuse
- LL-07: Recessed Light
- Panel A, 100A, 208/120V, 4W
- New Automatic Lighting Control Panel
- New Photo Cell Switch
- Panel B, 400A, 208/120V, 4W
- Panel C, 400A, 208/120V, 4W
- Chandelier Light

**GENERAL NOTES**

1. ALL LIGHTING FIXTURES AND ELECTRICAL EQUIPMENT ARE NEW.
2. ALL DESIGN AND CONSTRUCTION SHALL COMPLY WITH 2017 NEC.

**KEYNOTES**

- 1 NEW PANEL BOARD, SEE PANEL, SCHEDULE
- 2 NEW AUTOMATIC LIGHTING CONTROL PANEL "LC" RE-ROUTE ALL LIGHTING CIRCUITS THAT WILL BE CONTROLLED VIA TIMER TO THIS PANEL "LC"
- 3 NEW PHOTO CELL SWITCH ON ROOFTOP (TYP.)
- 4 NEW SWITCH PROVIDED WITH MOTION SENSOR
- 5 NEW EMERGENCY LIGHT, CONNECT TO SERVING-AREA CIRCUIT
- 6 PROVIDE J-BOX AND WIRING ABOVE CEILING FOR SIGN, SIGN TO BE PROVIDED BY OTHERS ON SEPARATED PERMIT (TYP.)
- 7 LIGHTING IS PROVIDED WITH COOLER/FREEZER SEE POWER PLAN
- 8 LIGHTS PROVIDED WITH HOOD, SEE POWER PLAN

**LIGHTING LOAD CALCULATIONS**

**COMcheck Software Version 4.1.5.5**  
**Interior Lighting Compliance Certificate**

**Project Information**  
Energy Code: 2012 IECC  
Project Title: DENNY'S RESTAURANT #9633  
Project Type: New Construction

Construction Site: 4248 S SIGNAL BUTTE RD, MESA, AZ 85212  
Owner/Agent:  
Designer/Contractor: DAVID GARCIA ACOSTA, GARDEL ENGINEERING, 441 S 48TH ST, TEMPE, AZ 85281, 480 361 3667, david@gardelengineering.com

Credits: 1.0 Required 0.0 Proposed

**Allowed Interior Lighting Power**

Area Category	A	B Floor Area (ft <sup>2</sup> )	C Allowed Watts / ft <sup>2</sup>	D Allowed Watts (B X C)
1-Restaurant (Dining: family)		4200	1.60	6720
				Total Allowed Watts = 6720

**Proposed Interior Lighting Power**

Fixture ID : Description / Lamp / Wattage Per Lamp / Ballast	A	B Lamps/ Fixture	C # of Fixtures	D Fixture Watt.	E (C X D)
1-Restaurant (Dining: family)					
EM LIGHT: Other		2	5	5	25
EM LIGHT W/ SIGN: Other		2	7	5	35
12"x12" SQ. LED. LED A Lamp 13W:		1	6	13	78
24" DRUM PENDANT LED: Other:		1	32	52	1664
6" WHITE REC. LED: Other:		2	30	10	300
2'x4' GRID FIXTURE: Other:		4	16	128	2048
6" EYE BALL FIXT.: Other:		1	9	9	81
				Total Proposed Watts =	4231

Interior Lighting PASSES: Design 37% better than code

**Interior Lighting Compliance Statement**  
Compliance Statement: The proposed interior lighting design represented in this document is consistent with the building plans, specifications, and other calculations submitted with this permit application. The proposed interior lighting systems have been designed to meet the 2012 IECC requirements in COMcheck Version 4.1.5.5 and to comply with any applicable mandatory requirements listed in the Inspection Checklist.

Name - Title \_\_\_\_\_ Signature \_\_\_\_\_ Date \_\_\_\_\_

Project Title: DENNY'S RESTAURANT #9633 Report date: 10/10/22  
Data filename: Untitled.cck Page 1 of 6

**LIGHTING FIXTURE SCHEDULE**

MARK	NEW/ EXISTING	FIXTURE DESCRIPTION	MANUFACTURER & MODEL	VOLTAGE	NUMBER OF LAMPS	LAMP TYPE	WATTAGE PER FIXTURE	MOUNTING	REMARKS
TA	NEW	2'x4' GRID FIXTURE	LITHONIA 2618-432-A12.1 25 W/QLT 1/4	120	4	F32T8	128	GRID	
LL-05B	NEW	6" WHITE RECESSED ROUND	B118-108-27X-8	120	2	FURNISHED	10	RECESSED	
LL-05C	NEW	6" WHITE RECESSED ROUND	B118-108-27X-8	120	2	FURNISHED	10	RECESSED	
LL-09	NEW	6" EYE BALL FIXTURE	HALO-78TRZ	120	1	LED	9	RECESSED	
LL-02B	NEW	24" DRUM PENDANT LIGHT	TAC5-24	120	1	LED	52	SUSPENDED	
LL-08	NEW	LOW PROFILE 12"x12" SQUARE	FM512-2-130T1	120	1	LED	13	GRID	
LL-07	NEW	EMERGENCY EXIT LIGHT WITH EXIT SIGN	BY CONTRACTOR	120	2	LED	5	SURFACE	PROVIDED WITH 90 MIN BATTERY BACKUP
LL-09	NEW	EMERGENCY LIGHT	BY CONTRACTOR	120	2	LED	5	SURFACE	PROVIDED WITH 90 MIN BATTERY BACKUP

PROJECT NO.: MRT2201  
DESIGNED BY: DG  
DRAWN BY: GB  
CHECKED BY: DG

NO.	REVISION	DATE

ENGINEERING SEAL  
  
 EXPIRES 09/30/23

**GARDEL** engineering  
 MECHANICAL & ELECTRICAL ENGINEERING  
 441 S. 48TH ST, SUITE 101  
 TEMPE, AZ 85281  
 OFFICE: (480)361-3667  
 MOBILE: (480)217-5853  
 WWW.GARDELENGINEERING.COM  
 THE INFORMATION CONTAINED ON THESE DRAWINGS IS THE PROPERTY OF GARDEL ENGINEERING, LLC AND SHALL NOT BE USED FOR ANY OTHER PURPOSE OTHER THAN ORIGINALLY INTENDED WITHOUT WRITTEN PERMISSION OF THE ENGINEER.

DENNY'S RESTAURANT #9633  
 MESA NEW BUILD  
 4248 S SIGNAL BUTTE RD  
 MESA, AZ 85212

PROJECT:  
 SHEET #:  
**E2**  
 SHEET TITLE:  
 ELECTRICAL LIGHTING PLAN



**KEYNOTES**

- 1 NEW SES, 600A, 208/120V, 3Ø, 4W, NEMA 3R, BRACED FOR 35KA-SEE ONE LINE PLAN.
- 2 NEW PANEL "A", 100A, 208/120V, 3Ø, 4W, NEMA 1, SEE PANEL SCHEDULE PLAN.
- 3 NEW PANEL "B", 400A, 208/120V, 3Ø, 4W, NEMA 1, SEE PANEL SCHEDULE PLAN.
- 4 NEW PANEL "C", 400A, 208/120V, 3Ø, 4W, NEMA 1, SEE PANEL SCHEDULE PLAN.
- 5 NEW LIGHT CONTROL PANEL "LC". SEE LIGHTING PLAN.
- 6 AUTOMATIC HOOD INTERLOCK CONTROL PANEL ICP, SEE CONTROL DIAGRAM.
- 7 LIGHTS PROVIDED WITH HOOD.
- 8 NEW 20A, 120V GFCI TYP.
- 9 MANUAL SWITCH MOUNTED ON HOOD.
- 10 PROVIDE 30A, 240V, 2-POLE, NMA 1, FUSED DISCONNECT SWITCH WITH FUSES AS NOTED.
- 11 LIGHTS AND SWITCHES PROVIDED WITH WALK-IN COOLER/FREEZER.
- 12 WIRING AND ANTI-SWEAT DOOR HEATERS PROVIDED WITH W.I.C./W.I.F.
- 13 PROVIDE 20A, 120V, GFCI DEDICATED TO CONDENSATE DRAIN PIPE HEATER.
- 14 FEEDER FROM INTERLOCK CONTROL PANEL ICP TO KEF-1 ON ROOFTOP.
- 15 FEEDER FROM INTERLOCK CONTROL PANEL ICP TO KEF-2 ON ROOFTOP.
- 16 FEEDER FROM INTERLOCK CONTROL PANEL ICP TO MUA-1 ON ROOFTOP.

**Electrical Wiring**

- Duplex Convenience Receptacle
- 20A, 120V GFCI Duplex Receptacle
- New SES 600A, 208/120, 4W
- Junction Box
- Manual Switch Mounted On Hood
- Toggle Switch- Single Way
- 30A, 240V, 2 Pole Fused Disconnect Switch
- Automatic Hood Interlock Control Panel ICP
- Lights Provided With Hood
- Duty/Data Outlet

- 147.6 FT
- 43.0 EA
- 5.0 EA
- 1.0 EA
- 10.0 EA
- 1.0 EA
- 2.0 EA
- 2.0 EA
- 1.0 EA
- 8.0 EA
- 8.0 EA

**ELECTRICAL POWER PLAN**  
SCALE: 1/4" = 1'-0"

PROJECT NO.: MRT2201  
DESIGNED BY: DG  
DRAWN BY: GB  
CHECKED BY: DG

NO.	REVISION	DATE

ENGINEERING SEAL

EXPIRES 09/30/23

**GARDEL**  
engineering

MECHANICAL & ELECTRICAL  
ENGINEERING

441 S. 48TH ST. SUITE 101  
TEMPE, AZ 85281  
OFFICE: (480)361-3667  
MOBILE: (480)217-5853

WWW.GARDELENGINEERING.COM

THE INFORMATION CONTAINED ON THESE DRAWINGS SUCH AS DATA, DESIGNS, AND CONCEPTS ARE PROPERTY OF GARDEL ENGINEERING, LLC AND SHALL NOT BE USED FOR ANY OTHER PURPOSE OTHER THAN ORIGINALLY INTENDED WITHOUT WRITTEN PERMISSION OF THE ENGINEER.

PROJECT: DENNY'S RESTAYRANT #9633  
MESA NEW BUILD  
4248 S SIGNAL BUTTE RD  
MESA, AZ 85212

SHEET #:  
**E3**  
SHEET TITLE:  
ELECTRICAL  
POWER PLAN

NO.	REVISION	DATE

ENGINEERING SEAL



MECHANICAL & ELECTRICAL ENGINEERING  
 441 S. 48TH ST. SUITE 101  
 TEMPE, AZ 85281  
 OFFICE: (480)361-3667  
 MOBILE: (480)217-5853  
 WWW.GARDELENGINEERING.COM

THE INFORMATION CONTAINED ON THESE DRAWINGS SUCH AS DATA, DESIGNS, AND CONCEPTS, ARE PROPERTY OF GARDEL ENGINEERING, LLC AND SHALL NOT BE USED FOR ANY OTHER PURPOSE OTHER THAN ORIGINALLY INTENDED WITHOUT WRITTEN PERMISSION OF THE ENGINEER.

PROJECT:  
 DENNY'S RESTAURANT #9633  
 MESA NEW BUILD  
 4248 S SIGNAL BUTTE RD  
 MESA, AZ 85212

SHEET #:  
**E4**  
 SHEET TITLE:  
 ELECTRICAL ROOFTOP PLAN

**KEYNOTES**

- 1 NEW 5-TON HEAT PUMP PACKAGE UNIT ON ROOFTOP.
- 2 NEW UP-BLAST EXHAUST FAN MOUNTED ON ROOFTOP FOR KITCHEN HOOD.
- 3 NEW MAKEUP AIR UNIT MOUNTED ON ROOFTOP FOR KITCHEN HOOD.
- 4 WALK-IN FREEZER'S CONDENSING UNIT W<100 LBS
- 5 WALK-IN COOLER'S CONDENSING UNIT W<100 LBS
- 6 ROOF ACCESS LADDER AND HATCH.
- 7 NEW UP-BLAST EXHAUST FAN MOUNTED ON ROOFTOP FOR DISH WASHER AT SCULLERY AREA.
- 8 PROVIDE 30A, 240V, 3-POLE, NEMA3R, FUSED SWITCH DISCONNECT.
- 9 PROVIDE 60A, 240V, 3-POLE, NEMA3R, FUSED SWITCH DISCONNECT.
- 10 PROVIDE 120V, GFCI, WEATHER PROTECTION RECEPTACLE, INSTALLED WITHIN 25' FROM HP1,2,3,4,5 EQUIPMENT.(TYP)

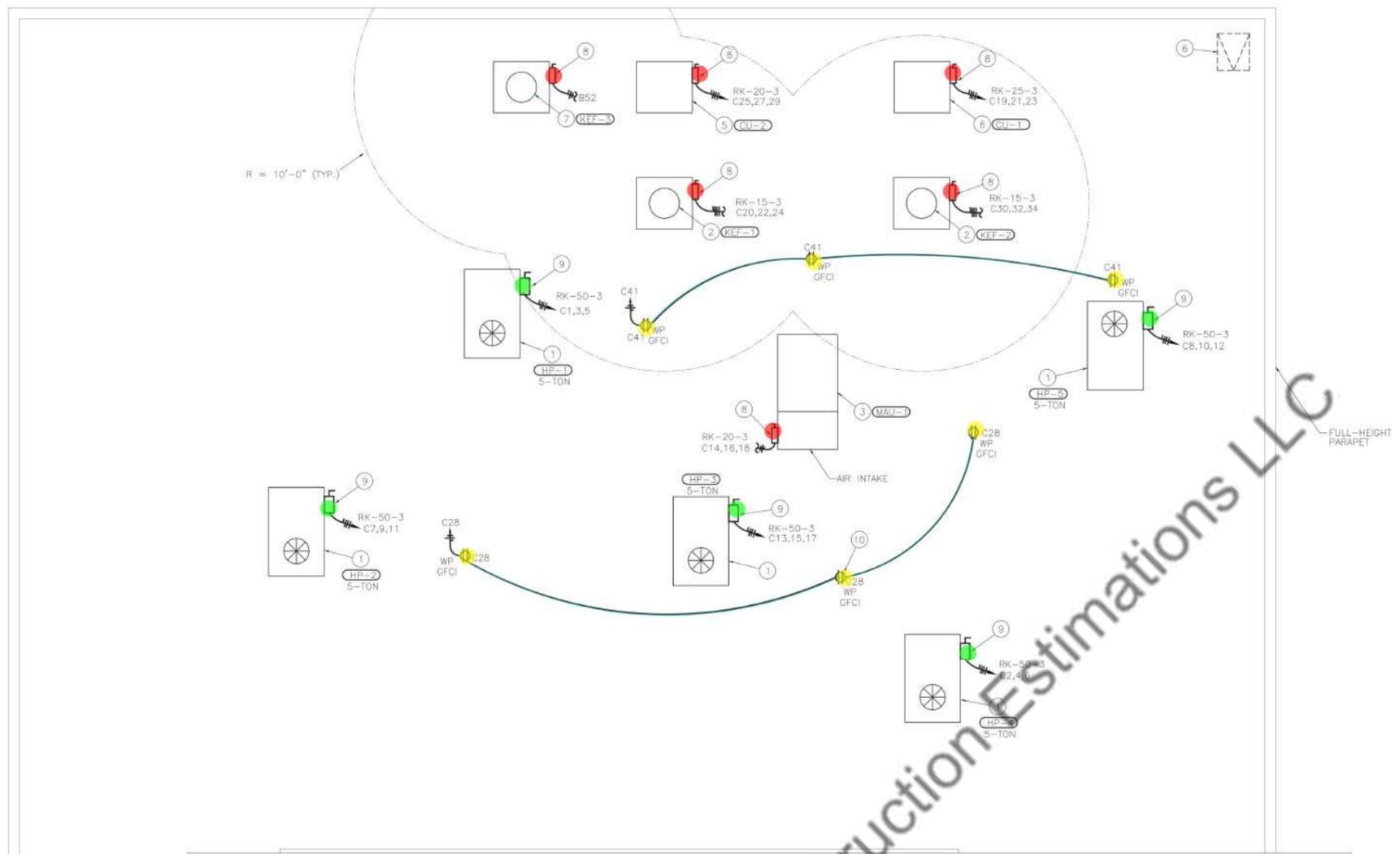

<ul style="list-style-type: none"> <li> Electrical Wiring</li> <li> 30A, 240V, 3 Pole Fused Disconnect Switch</li> <li> 60A, 240V, 3 Pole Fused Disconnect Switch</li> <li> 120V, GFCI Weather Protection Receptacle</li> </ul>	<ul style="list-style-type: none"> <li> 63.8 FT</li> <li> 6.0 EA</li> <li> 5.0 EA</li> <li> 6.0 EA</li> </ul>
---	---

**ELECTRICAL ROOFTOP PLAN**  
 SCALE: 1/4" = 1'-0"

NO.	REVISION	DATE

ENGINEERING SEAL



EXPIRES 09/30/23

**GARDEL**  
 engineering  
 MECHANICAL & ELECTRICAL  
 ENGINEERING  
 441 S. 48TH ST. SUITE 101  
 TEMPE, AZ 85281  
 OFFICE: (480)361-3667  
 MOBILE: (480)217-5853  
 WWW.GARDELENGINEERING.COM

THE INFORMATION CONTAINED ON THESE DRAWINGS SUCH AS DATA, DESIGN, AND CONCEPTS, ARE PROPERTY OF GARDEL ENGINEERING, LLC AND SHALL NOT BE USED FOR ANY OTHER PURPOSE OTHER THAN ORIGINALLY INTENDED WITHOUT WRITTEN PERMISSION OF THE ENGINEER.

DENNY'S RESTAURANT #9633  
 MESA NEW BUILD  
 4248 S SIGNAL BUTTE RD  
 MESA, AZ 85212

PROJECT:

SHEET #:  
**E7**  
 SHEET TITLE:  
 ELECTRICAL SITE PLAN &  
 ONE-LINE DIAGRAM

- New SES 600A, 208/120, 4W **1.0 EA**
- New Panel LC-1, Lighting Control **1.0 EA**
- Panel A, 100A, 208/120V, 4W **1.0 EA**
- Panel B, 400A, 208/120V, 4W **1.0 EA**
- Panel C, 400A, 208/120V, 4W **1.0 EA**
- New Underground 2" PVC Empty Conduit **10.0 FT**
- New Underground 3 1/2" PVC Empty Conduit **33.3 FT**
- 3" SCH40 PVC Empty Conduit **12.8 FT**

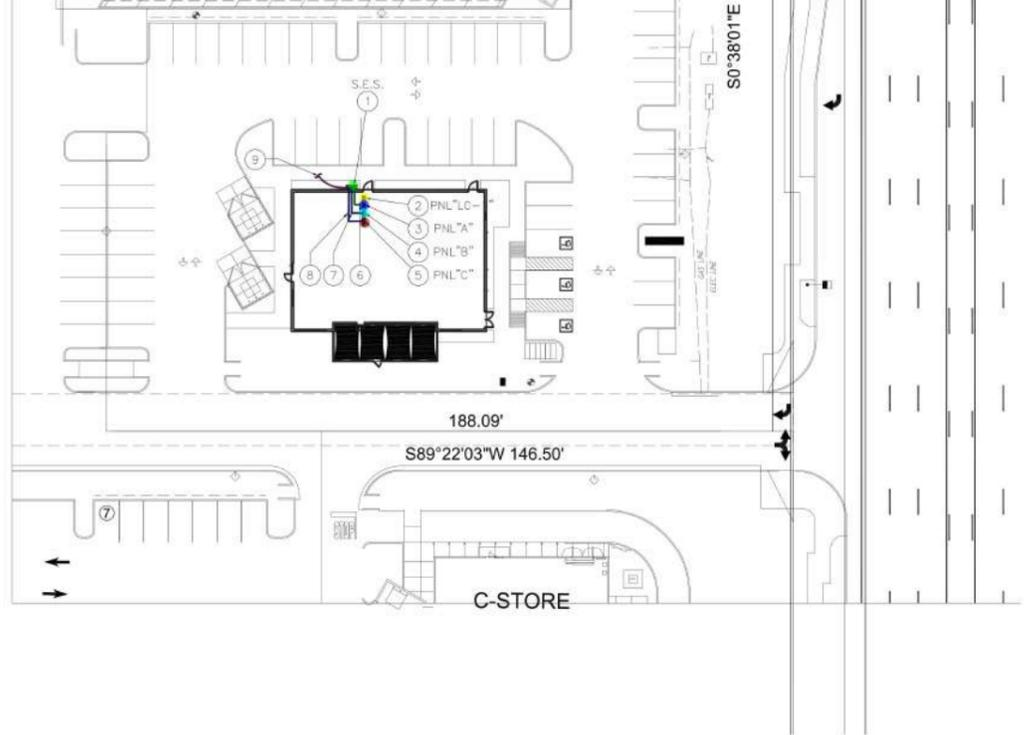

**ELECTRICAL SITE PLAN**  
 SCALE: 1/32" = 1'-0"

**KEYNOTES**

- 1 NEW S.E.S. RATED FOR 600A, 208 /120V, 3Φ, 4W, NEMA 3R, BRACED FOR 35KA. SEE ONE-LINE DIAGRAM.
- 2 NEW PANEL LC-1, LIGHTING CONTROL.
- 3 NEW PANEL "A", 100A, 208/120V, 3Φ, 4W, NEMA 1, SEE ONE-LINE DIAGRAM.
- 4 NEW PANEL "B", 400A, 208/120V, 3Φ, 4W, NEMA 1, SEE ONE-LINE DIAGRAM.
- 5 NEW PANEL "C", 400A, 208/120V, 3Φ, 4W, NEMA 1, SEE ONE-LINE DIAGRAM.
- 6 NEW UNDERGROUND 2" PVC EMPTY CONDUIT AT 24" BELOW GRADE.
- 7 NEW UNDERGROUND 3 1/2" PVC EMPTY CONDUIT AT 24" BELOW GRADE.
- 8 NEW UNDERGROUND 3 1/2" PVC EMPTY CONDUIT AT 24" BELOW GRADE.
- 9 NEW U.G. PRIMARY SERVICE TO TRANSFORMER PAD PER APS REQUIREMENTS, PROVIDE (2) 3" SCH40 PVC EMPTY CONDUIT AT -36" BELOW GRADE. CONTRACTOR SHALL COORDINATE WITH APS FOR FINAL ROUTE, LOCATION AND OTHER REQUIREMENTS OF EMPTY CONDUIT PRIOR CONSTRUCTION. CONTACT ENGINEER IN CASE OF ANY MAJOR CHANGES.

**LOAD CALCULATIONS**

CONNECTED LOAD AT PANEL "A"	= 71 A
CONNECTED LOAD AT PANEL "B"	= 220 A
CONNECTED LOAD AT PANEL "C"	= 238 A
<b>SUM</b>	<b>= 529 A</b>
<b>TOTAL</b>	<b>= 529 A</b>

EXISTING S.E.S. IS RATED AT 600A, 208/120V, 3Φ, 4W NEMA 3R

**ELECTRICAL LEGEND**

- S.E.S. SERVICE ENTRANCE SECTION
- PANEL BOARD / LOAD CENTER
- CEILING MOUNTED LIGHT FIXTURE.
- WALL MOUNTED LIGHT FIXTURE.
- JUNCTION BOX IN ACCESSIBLE LOCATION ABOVE REMOVABLE CEILING WITH FLEXIBLE CONDUIT CONNECTION TO LIGHT FIXTURE.
- FLUORESCENT LIGHT FIXTURE.
- FLUORESCENT STRIP FIXTURE.
- FLEX CONNECTION TO EQUIPMENT. LIQUID TIGHT FLEX WHERE EXPOSED TO WEATHER.
- JUNCTION BOX IN ACCESSIBLE LOCATION, NEMA 3R WHERE EXPOSED TO WEATHER.
- DUPLEX CONVENIENCE RECEPTACLE AT +18" OR AS NOTED.
- RECEPTACLE AT FLOOR.
- RECEPTACLE AT CEILING.
- DEDICATED RECEPTACLE.
- FOUR-PLEX CONVENIENCE RECEPTACLE AT 18" OR AS NOTED.
- SPLIT WIRED DUPLEX CONVENIENCE RECEPTACLE AT +18" OR AS NOTED.
- TOGGLE SWITCH - SINGLE POLE, THREE WAY, KEYED, FOUR WAY ("P" INDICATES ILLUMINATED HANDLE OR PILOT LIGHT, "m" motions SENSITIVE) AT +44" OR AS NOTED.
- MOTOR CONTROLLER, FURNISHED WITH EQUIPMENT.
- DISCONNECT SWITCH H.P. RATED, WITH DUAL ELEMENT TIME DELAY FUSED (CLASS RK1), NEMA 3R ENCLOSURE WHERE EXPOSED TO WEATHER. FUSE PER EQUIPMENT MANUFACTURER'S RECOMMENDATIONS. "F" INDICATES NON-FUSED.
- (M) MOTOR, SIZE AND RATING AS NOTED.
- TELE/DATA OUTLET @ +18" WITH 3/4" STUB ABOVE CEILING.
- TELE/DATA OUTLET @ 44" WITH 3/4" STUB ABOVE CEILING.

CIRCUIT IN CONDUIT, CONCEALED UNDER FLOOR. HASH MARKS INDICATES QUANTITY OF CONDUCTORS. NO MARKS INDICATE TWO CONDUCTORS, PLUS EQUIPMENT AND IG GROUNDS. (NOTE: WIRE AND OR CONDUIT SIZE SHOWN IN PARENTHESIS IS MINIMUM SIZE FOR ENTIRE CIRCUIT; 12# MINIMUM). LONG STROKES INDICATES NEUTRAL CONDUCTOR(S), SHORT STROKES INDICATES PHASE OR SWITCHED CONDUCTORS, (TYPICAL). EACH ISOLATED GROUND WIRE SHALL HAVE A SEPARATE NEUTRAL AND IG GROUND WIRE. GROUND WIRE(S) ARE NOT SHOWN ON DRAWINGS. GROUND WIRE SHALL BE INSULATED COPPER.

CIRCUIT INTERRUPTER, CONCEALED IN WALL OR ABOVE CEILING.

HOMERUN TO PANELBOARD, OR AS NOTED.

CONDUIT (EC) STUB-OUT. CAP AND MARK WITH APPROVED MARKER.

GFCI GROUND FAULT CIRCUIT INTERRUPTER

**ELECTRICAL NOTES (NOT ALL USED)**

CONTRACTOR TO PROVIDE AND INSTALL ELECTRICAL WORK, ACCORDING TO PLANS. RE-CONNECT ALL EXISTING LOAD TO NEW AND / OR EXISTING PANELS.

CONTRACTOR TO COORDINATE ELECTRICAL REQUIREMENTS FOR MECHANICAL AND PLUMBING WORK, PER 2017 N.E.C. AND APPLICABLE RULES, REGULATIONS, AND ORDINANCES.

CONTRACTOR TO TIE-IN EXISTING UTILITIES AND COMPLY WITH BUILDING CODE REQUIREMENTS.

CONTRACTOR TO TIE-IN TO EXISTING SERVICE PANEL AND COMPLY WITH NATIONAL ELECTRICAL CODE REQUIREMENTS.

GENERAL NOTE: CONTRACTOR SHALL BE RESPONSIBLE TO FIELD VERIFY DIMENSIONS OF SPACE AND QUANTITIES, SIZES, ETC. PRIOR TO CONSTRUCTION.

PROVIDE COPPER WIRE THHN / THHN #12 MINIMUM. CONDUITS SHALL BE EITHER RIGID OR EMT AS ALLOWED BY CODE. CONDUIT EXPOSED TO THE ELEMENTS OR BURIED UNDERGROUND SHALL BE WRAPPED WITH SCOTCH 51 TAPE OR EQUAL.

ALUMINUM CONDUCTORS ARE NOT ALLOWED UNLESS SPECIFICALLY APPROVED BY THE ARCHITECT IN WRITING BEFORE BIDDING THE JOB.

FOR RECEPTACLE HOMERUNS OVER 65 LINEAL FEET, USE #10 AWG WIRE. FOR RECEPTACLE HOMERUNS OVER 115 FEET IN LINEAL FEET USE #8 AWG WIRE.

EQUIPMENT, RACEWAYS, ETC. SHALL HAVE PROPER GROUNDING PER NATIONAL ELECTRICAL CODE.

BREAKERS THAT ARE TO BE APPROVED TO SUPPLY LIGHTING LOADS SHALL BE RATED FOR SWITCHING DUTY. PROVIDE HOT WIRE (NONSWITCHED) FOR THE NIGHT LIGHT CIRCUIT ALL NIGHT LIGHT SHALL ALSO HAVE AN EMERGENCY BALLAST FOR EMERGENCY LIGHTING.

PER 2112IRC, SEC E4002.14: PROVIDE TAMPER RESISTANT RECEPTACLES. IN AREAS SPECIFIED IN SECTION E3901.1, 125V, 15 AND 20 A RECEPTACLES SHALL BE LISTED TAMPER-RESISTANT RECEPTACLES.

**FAULT CURRENT CALCULATIONS**

FAULT POINT	EQUIPMENT	SHORT CIRCUIT AT BEGINNING OF RUN	LINE VOLTAGE	LENGTH OF RUN	REMARKS	CONDUCTORS				SHORT CIRCUIT CURRENT	
						NUM OF CONDUCTORS	SIZE	C	f		
1	PANEL "A"	29241	208	18		1	2 Cu	6044	0.725	0.579661	16950 A
2	LIGHT CONTROL PANEL "LC-1"	16950	208	5		1	12 Cu	617	1.321	0.430897	7304 A
3	PANEL "B"	29241	208	20		1	350 Cu	22736	0.214	0.823596	24083 A
4	PANEL "C"	29241	208	25		1	350 Cu	22736	0.309	0.763848	22336 A
5	INTERLOCK CONTROL PANEL "ICP-1"	22336	208	25		1	12 Cu	617	8.702	0.503071	2302 A

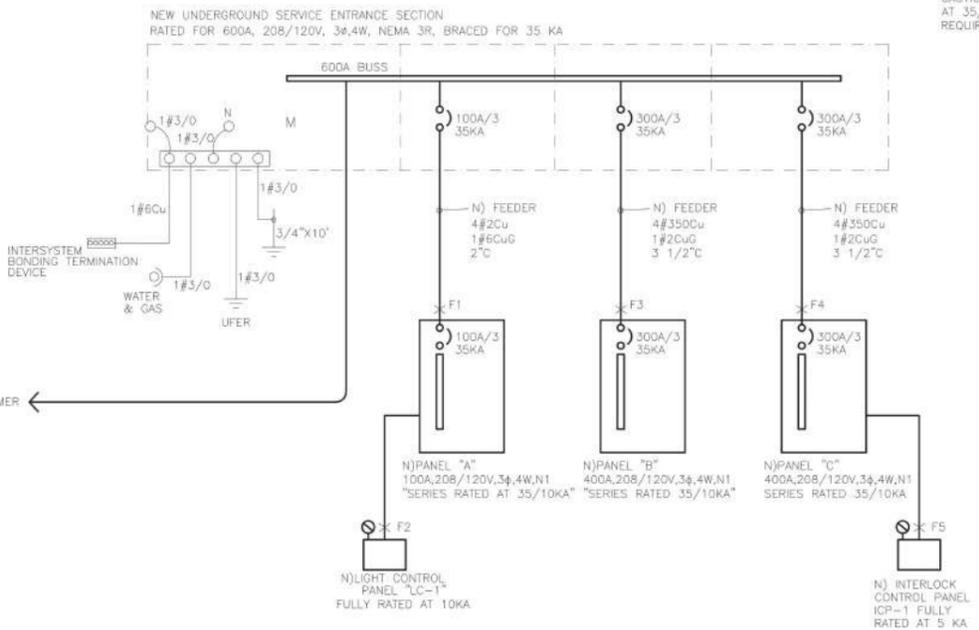

**PARTIAL ONE LINE DIAGRAM**

SCALE: NT 5

PROVIDE VISIBLE LABEL: CAUTION-TWO TIER SERIES COMBINATION SYSTEM RATED AT 35/10KA. IDENTIFIED REPLACEMENT COMPONENTS REQUIRED.

UTILITY CO. (SRP) TO PAD MOUNTED TRANSFORMER AF1= 29,241 A